

# **Introduction to Mechanical Engineering Design**

JACQULYN A. BAUGHMAN

Iowa State University Digital Press  
Ames, Iowa



*Introduction to Mechanical Engineering Design* by Jacquelyn A. Baughman is licensed under a [Creative Commons Attribution-ShareAlike 4.0 International License](https://creativecommons.org/licenses/by-sa/4.0/), except where otherwise noted.

*You are free to copy, share, adapt, remix, transform, and build upon the material, so long as you follow the terms of the license.*

*This is a publication of the*  
Iowa State University Digital Press  
701 Morrill Rd, Ames, IA 50011  
<https://www.iatatedigitalpress.com>  
[digipress@iastate.edu](mailto:digipress@iastate.edu)

# Contents

ME 270 Introduction 1: Course Description, Objectives, and Module Overview	1
--	---

## Module 00- Micro-economy Kit

Module 00: Overview	4
Micro-economy Kit Overview	8
Chapter 1: Developing Nations: Problems and Solutions	11
Chapter 2: Sustainability	14

## Module 1 - Define

Module 1: Overview	18
Define Phase	21
Chapter 1: Project Charter	22
Chapter 2: Project Plan Development	23
Example Project: Gearbox Subassembly, MPI, Drawing, and Video	25

## Module 2 - Measure

Module 2: Overview	27
Measure Phase	31
Chapter 1: Customer Requirements	32
Chapter 2: Market Analysis	36
Chapter 3: Engineering Characteristics/Specifications and Benchmarking	39

## Module 3- Analyze

Module 3: Overview	45
Analyze Phase	51
Chapter 1: Introduction to Form (Morphology) in Engineering Concept Generation	52
Chapter 2: Functional Analysis and Concept Generation	57
Chapter 3: QFD (House of Quality w/Decision Matrix) - HoQ w/DM	61
Chapter 4: Final Project Plan and Concept Presentation	68

## Module 4A - Design

Module 4A: Overview	71
Design Phase	76
Chapter 1: Modeling	78
Chapter 2: Design Failure Mode & Effects Analysis (DFMEA)	82
Chapter 3: Engineering Drawings and MPIs	86

## Module 4B - Design Continued

Module 4B: Overview	95
Design Phase Cont'd	101
Chapter 4: BOM, Purchase Order and Part Cost	102

## Module 5 - Verify

Module 5: Overview	104
Verify Phase	108
Chapter 1: Test Planning and Results	109
Chapter 2: Prototype Manufacture/Fabricate/Assemble	111

## Module 6 - Report Results

Module 6: Overview	114
Report Phase	120
Chapter 1: Design Results Reporting	121
Appendix 1: Accessibility Assessment	123

# ME 270 Introduction 1: Course Description, Objectives, and Module Overview

---

## ME 270 Course Description

**ME 270:** Introduction to Mechanical Engineering Design (3 Cr.)

**Prereq:** M E 160 or equivalent, M E 170 or equivalent, PHYS 221

**Course Description:** Overview of mechanical engineering design with applications to thermal and mechanical systems. Introduction to current design practices used in industry. Semester-long team project focused on addressing societal needs. Past projects include designing human powered charging systems and products for developing nations.

## ME 270 Course Learning Objectives (CLO)

- **CLO1:** Given an open-ended problem, students will apply the engineering design process and tools to generate a solution (Dr. Jacquelyn Baughman's sections only CLO)
- **CLO2:** Students will demonstrate effective teamwork and collaboration during the engineering design process
- **CLO3:** Students will be able to create technical reports that possess appropriate structure, grammar, and tone.
- **CLO4:** Students will be able to identify ways that social, economic, and environmental issues (three legs of the sustainability table) impact or are impacted by the activities of the designer.

**Watch the video below for an example of a team testing their solution prototype!** This video has no sound.

*One or more interactive elements has been excluded from this version of the text. You can view them online here:*  
<https://iastate.pressbooks.pub/me270baughman/?p=4#oembed-1>

## Module Objectives

1. **Module Objective 1:** Students will be able to describe an engineering problem (CLO1)
2. **Module Objective 2:** Students will recognize the three pillars of sustainability in design and impact on design decisions (CLO1, CLO4)
3. **Module Objective 3:** Students will recognize the design process and associated tools utilized in the course, Design for Six Sigma (DFSS) and DMADVR toolbox (CLO1)



## Module Highlights

This module contains learning content that is to be read/reviewed and watched (videos). The module contains interactive videos embedded within learning content, as well as, interactive activities for students to test their own understanding of the material. The interactive materials are not graded but for the students' own enhanced learning experience in testing their understanding. This module is a prerequisite and completion is required to view the next module's content learning content and associated activities.

In this module, students will gain an overall understanding of the course and the design process utilized, Design for Six Sigma. Students will be introduced to the DMADVR toolbox, utilized throughout the semester in completing design team assignments. The DMADVR toolbox video will provide students with an overview and guidance to its location in Canvas.



## Materials, Activities and Assignments

- Read/review learning module content in sequential order as setup in Canvas
- Watch embedded videos within learning modules and associated parts (1-3a)
- Complete all interactive learning activities within the learning module

**MODULE 00-  
MICRO-ECONOMY KIT**



# Module 00: Overview

---

## Module 00 Objectives

1. **Module Objective 1:** Students will be able to describe an engineering problem (CLO1)
2. **Module Objective 2:** Students will recognize the three pillars of sustainability in design and impact on design decisions (CLO1)
3. **Module Objective 3:** Students will be able to chose an appropriate design team role (CLO2)
4. **Module Objective 4:** Students will be able to function effectively in selected role (CLO2)



## Module Highlights

This module contains learning content that is to be read/reviewed and watched (videos). The module contains interactive videos embedded within learning content, as well as, interactive activities to test for understanding. The interactive materials are not graded. These activities are utilized for students' own enhanced learning experience. This module is a prerequisite and completion is required in order to view the upcoming learning content and associated activities.

In this module students will be able to recognize the 3 pillars of sustainability (sometimes referred to as the three legs of the sustainability table). This module contains several videos of innovative approaches that entrepreneurs took in solving a problem they discovered in their own country or developing country. Identifying a need and designing a solution that integrates sustainability while assisting impoverished populations. This module provides ideas for impoverished populations in which students can identify a profound need within a target market. This module will guide student teams in understanding the development of a micro-

economy kit. This module will allow students to communicate within their teams about their own skillsets. Identification of team strengths and weakness will be identified in order to allocate work for the semester long design project. The completion of this module is required to reveal the next learning module and associated activities. This module contains a quiz to be completed individually to prepare for teamwork.

Success involves team discussions around skill sets in order to allocate work throughout the semester. Identification of team roles is key to allocation of the team workload. Teams will get to practice this while completing assignments associated with this module.

## Materials, Activities and Assignments

- Read/review learning module content in order it is presented (setup in Canvas)
- Watch embedded videos within the learning modules parts
- Watch video with associated script at the end of the module
- Complete all interactive learning activities within the learning module
- DMADVR Toolbox templates associated with assignments
- Complete the associated learning module quiz to prepare for teamwork
- Submit associated Learning Module assignments per Canvas due dates

### Assignment: Team Norms

This assignment will provide students the opportunity to determine their role and associated responsibilities will be within the team. This will be based on typical roles found in industry-based project teams, and students will be able to develop team-based skills. Students will interact with team members to discuss their skills, abilities, and preferences in determining roles within the team. These roles are crucial to team-based work allocation to ensure the design project work is completed during the semester

This assignment will help you to develop...

- Module 01 Objective 1: Students will be able to chose an appropriate design team role (CLO2)

## Task

Students will need to review the roles provided in the assignment document and discuss their skills, knowledge, and preferences with other team members. Team members will collect contact information and determine how the team will interact, as well as, handle conflict.

In order to successfully complete this assignment , students will need to discuss/interact and agree to the roles/responsibilities for each team member. This interaction may take place in the classroom and on Microsoft Teams. The team will complete the DMADVR toolbox template and submit it to Canvas. Only one team member submits the team-based assignments for the team.

## Grading Criteria

Grading is based on the “Expectations of Deliverables” outlined in the assignment document. This is reflected in the grading rubric available to students on the Canvas once the assignment is opened.

## Assignment: Widget Drawing, Manufacturability, and Safety Training

This activity is will help you to develop...

- Module Objective 1: Students will be able to describe an engineering problem (CLO1)
- Module Objective 2: Students will recognize the three pillars of sustainability in design and impact on design decisions (CLO1)
- Module Objective 4: Students will be able to function effectively in selected role (CLO2)

## Task

The team will review a provided drawing of a ‘widget’ and modify it in order to manufacture a

minimum of 3 widgets. The team will work together to utilize Solidworks, a CAD software program utilized in Mechanical engineering to correct the drawing of the ‘widget’ and work with manufacturing (Boyd Lab) to obtain approval for manufacturability. The equipment and raw materials are contained in the Boyd Lab. The widget will be completed after the team members who are going to manufacture it are trained in the appropriate Boyd Lab equipment (typically the miter saw, drill press, and band saw). The team will determine at least 3 team members that will receive Shop Equipment Hands-on training, and all team members **MUST** complete Shop Safety Fundamentals online. Teamwork and collaboration will be keys to success with this assignment. The roles and responsibilities will allocate the workload as per team consensus.

## Grading Criteria

The grading rubric is based on the “Expectations of Deliverables” outlined in the assignment document. The rubric is available on Canvas once the assignment is opened.

# Micro-economy Kit Overview

---

## Student Design Team Goal in ME 270: Create a micro-economy kit (design project)

As an engineer, you directly touch people's lives by being instrumental in designing products! In ME 270, students work in teams and **engaged in creating a micro-economy kit (project) that encourages/promotes self-sustainability and economic growth for underdeveloped/developing nations**. In order to accomplish this task, your design team must:

1. **Perform research in order to identify a region/country and target population** who are experiencing a basic need shortcoming/issue/concern.
2. **Design an engineering solution (a product or process)** that would help the target population, and:
  - **Will allow them to redirect time and resources** to a different activity that positively impacts quality of life
  - **Meets** a basic need in a developing/underdeveloped nation
  - **Will improve or create** a self-sustaining economic activity
  - **Will be made from** a low cost kit, maximizing “local content/materials”
  - **Can be sold and serviced** by local artisans
  - **Promotes and integrates** sustainability

### Start simple.

Use resources immediately available to you. Befriend Google, the ISU Library, and search the following:

Review summaries at [World Bank](#), [United Nations](#), [World Health Organization](#), etc.

1. [TED videos](#) can be inspiring
2. Competitions (e.g., [Dell Social Innovation Challenge](#)) or Foundations (e.g., the [Gates Foundation](#)).
3. Data sources: [the CIA World Factbook](#), [Global Issues](#), etc.



Villagers in Nana Kenieba hook up 12 V batteries for lighting.

## Recommendations

1. Choose something inspiring that excites your team.
2. Perform research.
3. Select and target ONE region with a focused scope. Not the entire world, but a target customer.
4. learn about the regions of your interest. Become familiar with their history, culture, geography, economy and find more specific resources
5. Things won't be perfect the first time, iteration is to be expected, and is a beneficial learning process.

## Dos and Don'ts of Your Team's Engineering Design Project:

DOS	DON'TS
Include moving parts	Do not select a project that is "TOO easy" (such as a stove, grain storage, etc)
Design must involve experimentation via testing and learning	
Design MUST fit in the provided totes(assembled OR disassembled) as a SCALED down functional prototype of a larger product	Water treatment/filtration (DIFFICULT and expensive to test functionality, so not feasible in this course)

### Practice Exercise

An interactive H5P element has been excluded from this version of the text. You can view it online here:

<https://iastate.pressbooks.pub/me270baughman/?p=2232#h5p-1>

# Chapter 1: Developing Nations: Problems and Solutions

---

## Poverty

Many developing countries suffer from extreme poverty. These are the statistics from the [2018 Human Development Report by the UN Development Program](#) to show the multitude of ways in which poverty impacts the quality of human life.

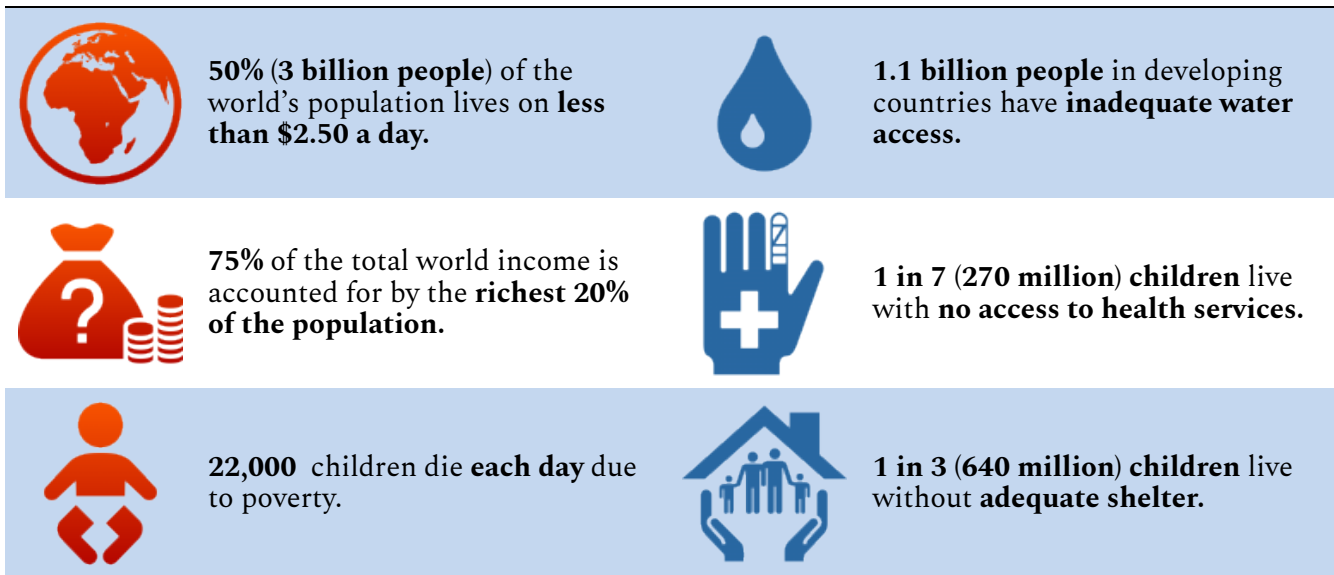

## The Underlying Problem

People of developing countries engage in resourceful and self-sustaining practices as a way to the cycle of poverty. Solutions to the problems of developing countries must be affordable, locally-based and renewable. Below are just some examples.



## Developing Nations: Problems and Solutions

### Problem 1: Lack of access to energy and electricity

- **Solution:** Use of wind to generate energy.

**Watch TED TALK 1 by:** Malawian inventor William Kamkwamba, who at 14 built an electricity-generating windmill from spare parts, working from rough plans he found in a library book.

*One or more interactive elements has been excluded from this version of the text. You can view them online here:*  
<https://iastate.pressbooks.pub/me270baughman/?p=29#oembed-1>

[How-I-built-a-windmill Ted-Talk Transcript \[DOC\]](#)

---

### Problem 2: Lack of access to clean water

- **Solution:** Use of a nanotech filter that could save lives in emerging economies and disaster sites.

**Watch TED TALK 2 by:** Engineer Michael Pritchard invented the portable Lifesaver filter, which can make the most revolting water drinkable in seconds.

*One or more interactive elements has been excluded from this version of the text. You can view them online here:*  
<https://iastate.pressbooks.pub/me270baughman/?p=29#oembed-2>

[Clean Water Everywhere Transcript \[DOC\]](#)

---

### Problem 3: Air pollution

- **Solution:** Use of clean-burning charcoal from farm waste in kitchens with open cooking fires.

**Watch TED TALK 3 by:** Amy Smith, the MIT Engineer, who presented a solution that could save 2 million children a year in the developing world.

*One or more interactive elements has been excluded from this version of the text. You can view them online here:*

<https://iastate.pressbooks.pub/me270baughman/?p=29#oembed-3>

[Simple Designs To Save A Life Transcript \[DOC\]](#)

---

## **Problem 4:** Access to quality health care

- **Solution:** Use of an inexpensive small sleeping bag for premature babies.

**Watch TED TALK 4 by:** Jane Chen, who showcases a solution that is cheaper than expensive incubators, but just as functional.

*One or more interactive elements has been excluded from this version of the text. You can view them online here:*

<https://iastate.pressbooks.pub/me270baughman/?p=29#oembed-4>

[A Warm Embrace That Saves Lives Transcript \[DOC\]](#)

# Chapter 2: Sustainability

---

An interactive H5P element has been excluded from this version of the text. You can view it online here:  
<https://iastate.pressbooks.pub/me270baughman/?p=520#h5p-37>

Sustainability is defined as “development that meets the needs of the present without compromising the ability of future generations to meet their own needs” (World Commission on Environment and Development, 1987).

Sustainability occurs when all three pillars (social, economic, and environmental) are thriving!

## Three Pillars Venn Diagram

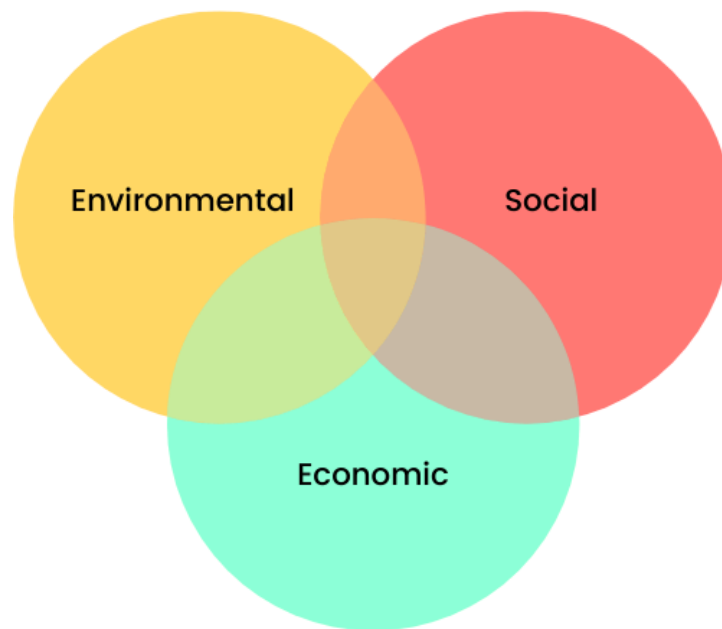

For more information about the three pillars model for sustainability, check out the following resources:

- [A Framework for Sustainability Indicators at EPA \[PDF\]](#)
- [EPA Sustainability Primer \[PDF\]](#)

## Practice Exercise

Drag the components into the sections they correspond with:

*An interactive H5P element has been excluded from this version of the text. You can view it online here:*  
<https://iastate.pressbooks.pub/me270baughman/?p=520#h5p-77>

## Customer Needs – Sustainability

Majd Mashharawi was walking through her war-torn neighborhood in Gaza when an idea flashed in her mind: “What if she could take the rubble and transform it into building materials?”

*One or more interactive elements has been excluded from this version of the text. You can view them online here:*  
<https://iastate.pressbooks.pub/me270baughman/?p=520#oembed-1>

[How I made Bricks out of Ashes and Rubble Ted Talks Video Script \[DOC\]](#)

## OPTIONAL: A Sustainability Guide by Dassault System's (c) (Solidworks)

The idea of “Sustainable Design” is cropping up more and more in today’s product design conversations. But what is sustainable design, and how do I do it? [The Solidworks Sustainability Guide](#) provides some answers to these questions.

**Note:** Going through the entire Guide — and playing with some of the examples on Solidworks — should take about 5-7 hours, so it’s a good idea to pace yourself.

**Did you complete the entire guide with Solidworks?** You may be interested in taking the Solidworks CSWA-Sustainability Exam now.

“The completion of the Certified SOLIDWORKS Associate Sustainability (CSWA-Sustainability) exam shows that you have successfully demonstrated your understanding of the principles of environmental assessment and sustainable design. Employers can be confident that an individual with this certification understands the principles of environmental assessment and sustainable design.”<sup>1</sup>

---

1. Courtesy of Solidworks CSWA-Sustainability (c): [https://www.solidworks.com/sw/support/14672\\_ENU\\_HTML.htm](https://www.solidworks.com/sw/support/14672_ENU_HTML.htm)

# **MODULE 1 - DEFINE**

# Module 1: Overview

---

## Module Objectives

1. **Module Objective 1:** Students will be able to describe an engineering problem using a project charter (CLO1)
2. **Module Objective 2:** Students will be able to apply project management tools to meet deadlines (CLO1, CLO2)
3. **Module Objective 3:** Students will be able to explain/communicate the impact of incorporating the three pillars of sustainability in the final design (CLO4)
4. **Module Objective 4:** Students will be able to function effectively in selected role (CLO2)



## Module Highlights

In this module, student teams will review/read materials and watch videos embedded into the learning content. This module contains an e-book that will provide a background on poverty, and also contains an important industry-based video on the Project Charter and project planning (Vermeer Co.). There are interactive videos and students will be able to individually prepare by completing the module in sequential order as setup in Canvas. By utilizing the non-graded test for understanding interactive activities, students will be prepared to work in their teams on the assignments in order to turn them in on the due date provided in Canvas. The student teams will use the DMADVR toolbox, provided in Canvas, to complete the necessary template(s) for the Project Charter. The student teams will complete their initial project plan utilizing Microsoft Project Professional. Teams will progress through the team development process, and implement their roles/responsibilities in the project plan. Student team will complete an initial project plan using MS Project Professional.

Teams will review and discuss available project ideas provided by a GMO, reach consensus in order to select a semester project, and perform research to fully complete their Project Charter.

## Materials, Activities and Assignments

Required materials, activities and assignments

- Read/review Module 1 content in sequential order as setup in Canvas to obtain visibility of associated Quiz and Assignment(s)
- Watch embedded videos within Module content
- Complete the module quiz by Canvas due date
- Discussions in-class and on MS Teams regarding the project ideas, and select semester project through consensus
- DMADVR Toolbox Template(s) associated with Assignment(s)
- Complete and submit the Module 1 assignment:

### Project Charter and Initial Project Plan

This assignment will entail completing a project charter, which is the foundation for the design project. This guides the team's semester work, and is a living document. This assignment will help you to develop...

- **Module Objective 1:** Students will be able to describe an engineering problem using a project charter (CLO1)
- **Module Objective 2:** Students will be able to apply project management tools to meet deadlines (CLO1, CLO2)
- **Module Objective 3:** Students will be able to explain/communicate the impact of incorporating the three pillars of sustainability in the final design (CLO4)
- **Module Objective 4:** Students will be able to function effectively in selected role (CLO2)



## Task

It is important for the team's success to develop a charter to guide your semester work. Gaining experience in achieving consensus on the charter and initial project plan content is crucial in the team development process. The completion of the foundation pieces of the project, the charter and project plan, will ensure successful guidance is provided for the rest of the team's work during the semester. Utilizing the DMADVR Project Charter template and MS Project Professional will be key in completing and submitting the assignment on time.

## Grading Criteria

The grading/assessment is outlined in the assignment document's "Expectations of Deliverables", which is reflected in the rubric. The rubric is provided on Canvas and can be reviewed once the assignment is opened.

# Define Phase

---

**Define the project. Identify a target region and population. Understand the voice of the customer (VOC) to identify their needs. Provides a purpose/reason for the project with quantifiable data and measurable target.**

This phase starts by defining customer needs. The customer in most cases is an external entity, but customers can also be internal. For example, when designing a process that feeds components to another in-house process, the customer is internal.

The best sources for this information are the customers themselves. Make note of what they say they want, as well as what their own objectives are. For example, a customer may say a left-handed widget is needed, but after listening to what they need the widget to do, you might determine that a Teflon-coated left-handed widget might be a better solution. Discuss your ideas with the customer to define the best possible solution for the customer's actual needs.

Information that can be used to define what the customer needs might also come from industry research, historical data, sales department, and research your team has done. Whatever the source of information, the objective is to have the product design be primarily driven by what the customer needs and is willing to pay for.

# Chapter 1: Project Charter

---

*An interactive H5P element has been excluded from this version of the text. You can view it online here:*

<https://iastate.pressbooks.pub/me270baughman/?p=298#h5p-18>

## Practice Exercise

*An interactive H5P element has been excluded from this version of the text. You can view it online here:*

<https://iastate.pressbooks.pub/me270baughman/?p=298#h5p-20>

# Chapter 2: Project Plan Development

---

**A project plan** is often presented as a Gantt chart (schedule) showing the timeline or due dates. All projects have clearly defined start and end dates! A project plan is comprised of both the work breakdown structure (WBS) and the Gantt chart. These are two foundation parts needed in developing a project plan. It serves as a roadmap showing the project phases, key activities, and their start and end dates, dependencies between tasks, and project milestones. Project plans are typically presented as just the Gantt chart as a summary format to various audiences.

## Watch the interactive video below:

*An interactive H5P element has been excluded from this version of the text. You can view it online here:*

<https://iastate.pressbooks.pub/me270baughman/?p=384#h5p-38>

## In ME 270:

- The project phases are:
  - Define,
  - Measure,
  - Analyze,
  - Design,
  - Verify, and
  - Report (DMADVR)
- The details of tasks/activities are commonly referred to as the work break down structure (WBS), to ensure responsibilities and deadlines are identified.
- In MS project the WBS drives Gantt chart development.
- In developing a full project plan:
  - The WBS is determined
  - The GANTT chart is developed (as a result of WBS inputs)
- At Iowa State University students have access to MS Project in computer rooms, classroom computers, and the ability to download it to laptops/tablets through the IT services website. It is a great professional tool to have in a design engineer's toolkit. It will be a great bonus to place on your resume as you seek internships, co-ops, and your

first employment opportunity upon graduation.

## Practice Exercise

**Check your understanding with the activity below:**

*An interactive H5P element has been excluded from this version of the text. You can view it online here:*

<https://iastate.pressbooks.pub/me270baughman/?p=384#h5p-42>

# Example Project: Gearbox Subassembly, MPI, Drawing, and Video

---

- [Drwg – AN00009 \(Gearbox Subassembly\) \[PDF\]](#)
- [MPI – AN00009 \(GEARBOX SUBASSEMBLY\)C\[PDF\]](#)
- [ME270 Solidworks Video Tutorials Suggested List – S20 \[DOC\]](#)

*One or more interactive elements has been excluded from this version of the text. You can view them online here:*

<https://iastate.pressbooks.pub/me270baughman/?p=1933#oembed-1>

[AN00009 – Gearbox Subassembly Video Script \[DOC\]](#)

# **MODULE 2 - MEASURE**

# Module 2: Overview

---

## Module Objectives

1. **Module Objective 1:** Students will be able to define customer requirements (CLO1)
2. **Module Objective 2:** Students will be able to perform a market analysis (CLO1)
3. **Module Objective 3:** Students will be able to develop engineering specifications and benchmarking (CLO1)
4. **Module Objective 4:** Students will be able to function effectively in selected role (CLO2)
5. **Module Objective 5:** Students will be able to prepare structured summaries of design tool use and results that possess appropriate structure, grammar and tone (CLO3)



## Module Highlights

This module consists of material to review/read and videos that consist of both interactive and quiz-based activities. All module interactive activities provide the students to test their understanding, and is not graded. Students need to progress through the material in sequential order, as setup in Canvas. Once the module is completed, the quiz and associated assignments become visible, and are to be completed per Canvas due date. This module's material contains learning content about customer requirements, marketing analysis, and engineering specifications with benchmarking. This allows student teams to work on measuring their project by defining their target market's requirements, perform a market analysis, and to develop engineering specifications along with benchmarking competition. The module also provides students with an industry perspective (Vermeer Co.).

In this module student teams will continue to work through the DFSS process by utilizing the templates/forms found in the DMADV toolbox to complete their assignments. Teams will be successful by utilizing roles/responsibilities and allocating the workload to successfully



complete the assignment(s) on time in order to submit to Canvas. Student teams frequently forget to complete their summary, which is part of their final report. Success will hinge on completing the module and completing the quiz to be ready for teamwork!

## Materials, Activities and Assignments

- Read/review the module in sequential order
- Watch embedded videos in the module
- Complete interactive activities and quiz-based videos in the module
- Discuss assignment requirements and allocate workload within the team to complete assignments via in-class and MS Teams
- Submit associated assignments to Canvas due dates:

### Customer Requirements\_ Market Analysis

This assignment will provide students the opportunity to research and record customer requirements, and market competition. The teams need to allocate workload on the tasks, based on roles/responsibilities. This assignment provides the opportunity for consensus building and team collaboration completing the associated DMADVR toolbox templates.

This assignment will help you to develop...

- **Module Objective 1:** Students will be able to define customer requirements (CLO1)
- **Module Objective 2:** Students will be able to perform a market analysis(CLO1)
- **Module Objective 4:** Students will be able to function effectively in selected role (CLO2)
- **Module Objective 5:** Students will be able to prepare structured summaries of design tool use and results that possess appropriate structure, grammar and tone (CLO3)

### Tasks

Teams will work on developing customer requirements based on research (guided by –customer needs) to guide design. Teams need to utilize their roles and responsibilities to allocate work on this

assignment. The second part of this assignment is for teams to analyze the market based on target customers and to identify potential competitive products/ services. The team will gain information from this competitive analysis to consider how and if the customer needs are being met by the competition, and this will be valuable for teams in developing their own design. This will be used as input into the Engineering Specifications and Benchmarking assignment. Determining gaps in the market in meeting customer needs is key in future work in developing an engineering solution/design. Teams will gain experience with consensus building and work allocation. Teams will complete the associated DMADVR toolbox templates associated with the assignment(s).

Keys to success on this project include teamwork. Determining work allocation after a team discussion on the assignment requirements, and utilizing the DMADVR toolbox templates to complete the work. Inside and outside class discussion and work may be warranted to ensure due date is met. Success will hinge on completing the module and associated quiz to be ready for teamwork!

## Grading Criteria

Grading is based on the “Expectations of Deliverables” outlined in the assignment document. This is reflected in the grading rubric available to students on the Canvas once the assignment is opened.

## Engineering Specification and Benchmarking

The next step in the design process is to build a technical list of metrics and features that satisfy your customer requirements can be satisfied. In this assignment the team will work to build the list of metrics and features to satisfy the customer requirements. Customer requirements was developed previously in 03, and this serves as the WHAT, and in this assignment, teams need to develop the HOW those requirements will be satisfied.

This assignment will help you to develop...

- **Module Objective 3:** Students will be able to develop engineering specifications and

benchmarking (CLO1)

- **Module Objective 4:** Students will be able to function effectively in selected role (CLO2)
- **Module Objective 5:** Students will be able to prepare structured summaries of design tool use and results that possess appropriate structure, grammar and tone (CLO3)

## Tasks

This assignment will consist of teams acquiring information that will be used for decision making and product testing. Teams will determine the *technical* specifications required to meet customer requirements. Teams will review existing products and clearly define how they meet customer requirements. Teams will be successful in collaborating and having discussions to determine work allocation by utilizing roles/responsibilities. Teams will need to complete the associated DMADV toolbox template and allocate work to complete the assignment on time. Success will hinge on completing the module and associated quiz to be ready for teamwork!

## Grading Criteria

Grading is based on the “Expectations of Deliverables” outlined in the assignment document. This is reflected in the grading rubric available to students on the Canvas once the assignment is opened.

# Measure Phase

---

The second process step in Design for Six Sigma process, DMADV, it is used to determine the definition of what the customer wants to create a specification. The specification defines the product or service in a way that is measurable, allowing data to be collected and compared with the specified requirements. This is essential for ensuring the final product meets the customer needs, defined in the first step

Measure the customer requirements. Understanding customer needs/wants, and translating into measurable design requirements. This phase includes development of Customer Requirements, Market Analysis, Engineering Specifications, and Benchmarking.

*One or more interactive elements has been excluded from this version of the text. You can view them online here:*

<https://iastate.pressbooks.pub/me270baughman/?p=2249#oembed-1>

[Customer Needs – Part 1 Video Script \[doc\]](#)

# Chapter 1: Customer Requirements

---

## The Voice of the Customer

*An interactive H5P element has been excluded from this version of the text. You can view it online here:*

<https://iastate.pressbooks.pub/me270baughman/?p=257#h5p-54>

Watch Amos Winter's video below on the Leveraged Freedom Chair. The engineering design team's research revealed that:

- 40 million people in the developing world in dire need of functional inexpensive wheelchairs. Tanzania is one example of a target market
- By listening to the Voice of The Customer (VOC), design team identified customer wants/needs. These “raw” needs/wants were translated into Customer Requirements (CRs)

*One or more interactive elements has been excluded from this version of the text. You can view them online here:*

<https://iastate.pressbooks.pub/me270baughman/?p=257#oembed-1>

[The cheap all-terrain wheelchair Ted Talks a Video Script \[DOC\]](#)

## Customer requirements:

- Technical or non-technical descriptions of what a customer wants, needs, and/or desires.
- Not meeting customer requirements leads to market failure.

## Customer Needs vs Customer Requirements

Customers have needs and requirements. A customer *need* establishes the relationship between the organization and the customer (Example: “I need/want an iPad.”)

Requirements are those characteristics that determine whether or not the customer is happy. (Examples: iPad is user-friendly, has to be fast in data storage and retrieval, light-weight, long battery life, etc.)

You can measure user-friendliness with a Likert scale (1-5), measure download/upload in megabits per second or load times in fractions of seconds, light-weight can be a % or amount measured as a reduction from current weight.

## Voice of the Customer (VOC) and translation to specifications:

If you asked your customers what they wanted from your design, how would they answer? They often use descriptive, rather than quantifiable, words for voicing specifications:

- People considering a new car may want a “roomy” vehicle to store groceries, luggage, etc.
- People typically don’t provide specific quantification for “roomy”, such as interior volume or interior geometry in mind.
- Do not shy away from including qualitative requirements.

*An interactive H5P element has been excluded from this version of the text. You can view it online here:*

<https://iastate.pressbooks.pub/me270baughman/?p=257#h5p-19>

## Understand Your Customers

Design teams must understand the target market customers well in order to meet their expectations. Examples of not meeting the target customers’ expectations are seen as glaring

market failures. These can cost a company \$\$! It takes significant amounts of time, money, and effort to overcome the negative image of market failures.

*One or more interactive elements has been excluded from this version of the text. You can view them online here:*

<https://iastate.pressbooks.pub/me270baughman/?p=257#oembed-2>

[Domino's Pizza Greatest Turnaround Video Script \[DOC\]](#)

*One or more interactive elements has been excluded from this version of the text. You can view them online here:*

<https://iastate.pressbooks.pub/me270baughman/?p=257#oembed-3>

[Customer Needs – Part 2 Video Script \[DOC\]](#)

**IN ME 270, ONLY THE RANKING NUMBERS: 1,3,9 are used to rank customer requirements!**

## Practice Exercise

### Let's Look at MIRE TECH

To build a House of Quality, your team must determine customer requirements and then perform a market analysis. Below, match a customer need with a customer requirement:

*An interactive H5P element has been excluded from this version of the text. You can view it online here:*

<https://iastate.pressbooks.pub/me270baughman/?p=257#h5p-21>

## Practice Exercise

*An interactive H5P element has been excluded from this version of the text. You can view it online here:*

<https://iastate.pressbooks.pub/me270baughman/?p=257#h5p-22>

## Practice Exercise

### Customer Requirements

Customers provided importance rankings for their requirements and the top 2 were:

- Good Texture
- Generous Portions.

Appetizing Appearance was least important.

Finally, Good Taste and Low Prices were moderately important.

Given this information, rank your CRs (items of the same rank will be in the same order as was just listed):

*An interactive H5P element has been excluded from this version of the text. You can view it online here:*

<https://iastate.pressbooks.pub/me270baughman/?p=257#h5p-23>



# Chapter 2: Market Analysis

---

## Research Market Competitors – Benchmarking

In researching the market, your team needs to understand the customer’s experience(s) with existing products on the market. These competitors are then assessed using CRs. The idea is for your design team to understand the customer’s current experiences, or what products they are using to satisfy their requirements. This gives the opportunity for your design team to see what kind of product you can design to better satisfy the customer, so you can capture the market!

*One or more interactive elements has been excluded from this version of the text. You can view them online here:*  
<https://iastate.pressbooks.pub/me270baughman/?p=259#oembed-1>

[Benchmarking Video Script \[DOC\]](#)

## Let’s take a look at MIRE\_TECH’s competitor assessment/analysis from the HoQ:

The team identified four competitors to assess using the customer requirements with rankings of 1, 3, and 9:

**Table 1. Stove Reviews**

<b>Chitetezo mbaula</b>	<b>Weber-741001 Grill</b>	<b>Greenfire Stove</b>	<b>Rocket Stove</b>
9	1	1	9
9	3	9	3
9	9	9	3
9	9	3	3
3	9	3	9
3	1	1	3



**Table 2. Cookie Reviews**

Mrs. Field's	Girl Scout's	Starbucks	Cinnabon
3	3	3	9
3	3	3	3
3	3	3	3
3	1	1	1
3	3	9	9

### Practice Exercise

Answer this practice question about the cookie design team's assessment:

*An interactive H5P element has been excluded from this version of the text. You can view it online here:*

<https://iastate.pressbooks.pub/me270baughman/?p=259#h5p-52>

Occasionally, ranking numbers besides 1, 3, 9 are used by different entities. In ME design, we ONLY use 1, 3, and 9 for ranking.

### Practice Exercise

Watch the following interactive video: Developing a Deep Understanding of the Customer – Tools and Methods

*An interactive H5P element has been excluded from this version of the text. You can view it online here:*

<https://iastate.pressbooks.pub/me270baughman/?p=259#h5p-80>

# Chapter 3: Engineering Characteristics/ Specifications and Benchmarking

---

## Benchmarking and Engineering Specification

**Click on the left arrow to see each definition!**

An interactive H5P element has been excluded from this version of the text. You can view it online here:  
<https://iastate.pressbooks.pub/me270baughman/?p=309#h5p-48>

## Determining the How

Once the design team has identified the **WHO** (customer) and **WHAT** (customer requirements), the next step is to determine the **HOW**. As engineers, the team will need to develop engineering characteristics/features/functions to satisfy the customer.

For example, consider designing a new vehicle. A **stated need/want** by the customer might be,

“I need a lot of room in my car because I have two kids and a dog and we take cross-country trips”.

This translates into the **customer requirement** :

*The car must be **roomy**.*

To engineer a vehicle that meets this customer requirement, we must cast “roomy” into quantitative metrics or design features that we can:

1. **Assess** “on paper” using our modeling skills;
2. **Measure** once prototypes and production versions of our design are built;
3. **Justify** our choices to management.

**Suitable “metrics” might be:**

- “Rows of seats (#)”
- “Interior volume (cubic feet)”
- “Headroom (inches),” etc.

**A corresponding feature might be:**

- “Fold down seats.”

Note each metric has an associated unit. Specific features may or may not exist, and thus have no units. The list of design criteria should be based on careful analysis of the customer’s wants/needs, analysis of existing products and systems, and extensive discussion amongst the team.

In summary, **HOW** refers to:

**The technical features, functionality, and characteristics that meet customer requirements,** which form the “attic “of the house or How to Satisfy the Customer. The Relationship Matrix room of the House is used to assess these using the Customer Requirements using 1, 3, and 9. This is shown in your DMADVR Toolbox, in the tab titled, QFD w\_DM.

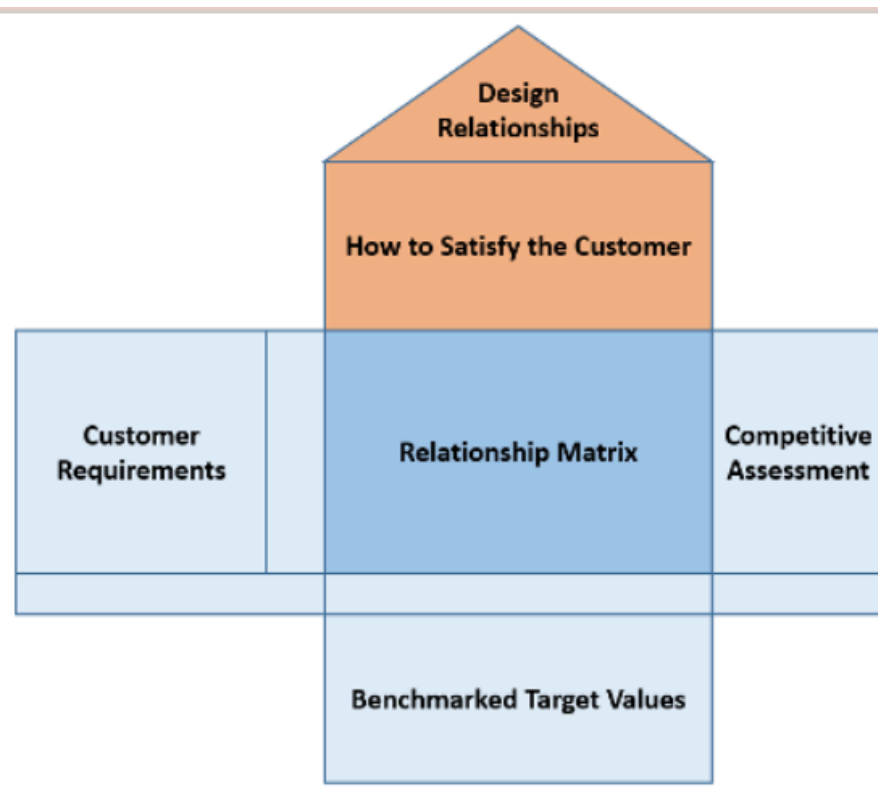

**House of Quality Rooms**

## Let Us Revisit MIRE TECH

The MIRE TECH design team first developed their customer requirements (CR) and rankings. Next, the team brainstormed engineering features/characteristics/functions that would satisfy these customer requirements. Asking HOW around the CRs assisted the team in developing the engineering features/characteristics/functions. The team brainstormed a list of quantifiable metrics and/or features that can be correlated to the customer requirements. Each metric must have an associated unit. If there is an “industry standard” definition of a particular metric, use the standard metric.

## Specifications and their Importance

*An interactive H5P element has been excluded from this version of the text. You can view it online here:*

<https://iastate.pressbooks.pub/me270baughman/?p=309#h5p-56>

Now let’s take another look at our design team’s development of a new chocolate chip cookie. The design team gathered information from the voice of the customer and determined the Customer Requirements and their rankings.

Now the Chocolate Cookie Design (CCD) team can brainstorm around Engineering Specifications (functions/features/characteristics) to determine HOW the CRs will be satisfied by your CCD engineering team.

### Voice of the Customer: Customer Requirements

Ranking	Based on Customers’ needs/wants, Define Customer Requirements
9	Good Texture
9	Generous Portions
3	Taste Good
3	Low Price
1	Appetizing Appearance

*An interactive H5P element has been excluded from this version of the text. You can view it online here:*

<https://iastate.pressbooks.pub/me270baughman/?p=309#h5p-49>

Now, the team needs to relate the customers' requirements to the engineering metrics and features. This is a team decision based on thoughtful discussions and research in order to justify the correlations. This is sometimes referred to as **the correlation or relationship matrix** of the House of Quality.

MIRE TECH Design Team used the following scale **to assess/rank the relationship** between CRS (*What*) and the Engineering Specifications, Features, Functions, and Characteristics:

- 9 – Strong relationship
- 3 – Moderate relationship
- 1 – Little to no relationship

*An interactive H5P element has been excluded from this version of the text. You can view it online here:*

<https://iastate.pressbooks.pub/me270baughman/?p=309#h5p-70>

## House of Quality: How It is Built

*An interactive H5P element has been excluded from this version of the text. You can view it online here:*

<https://iastate.pressbooks.pub/me270baughman/?p=309#h5p-59>

## Units of Measurement

Additionally, each /function/characteristic can be assessed in terms of their “direction”, up or down. In other words, from an engineering perspective, are you increasing or decreasing performance when meeting each Customer Requirement. A House Of Quality format is not always uniform. Some formats place units in the attic (top center) or foundation (bottom center). Some use up and down arrows vs. +/- . It is important that you review the form provided in the course to ensure compliance.

## Target Values

The House of Quality (HoQ) provides a foundation to use benchmarked or target values as objective measurements to evaluate each characteristic, forming the basement of the house (8.). Compare competition by benchmarking against Engineering Specifications.

Mire Tech Team has calculated the ranking shown in the spreadsheet below, Mire\_Tech\_QFD (House of Quality\_with DM). **Download** the spreadsheet below. Review how the rankings are automatically calculated based on your assessments already provided for the **WHAT** and **HOW** in the middle top area of the House of Quality (HoQ). Remember that the WHAT is the customer requirements or What the customer Wants! Also, the HOW is how your design team will satisfy or address What the Customer wants!

- [Click this link to download/view the Mire Tech QFD\(House of Quality\) with DM \[XLSX\]](#)

MIRE\_TECH completed sections 1, 2, 6, 7, 4, and 8. At the bottom of 4. Competition and Concepts are the scores for each of the Competitors and Concepts (Your team's). In green highlight are the high scorers, and can be used to develop the Benchmarking data!

Review the WHAT (Customer Requirements on the left side. There are two customers: the end user and the entrepreneur. Reviewing the spreadsheet from left to right the Customer Requirements or the WHAT rows are addressed by the HOW columns. This is the process for engineering design teams to understand WHAT the customer requires/wants and HOW the team will address this in their design.

**Occasionally, company cultures allow more than 1,3,9 ranking. It is rare, and won't be used for ME design courses.**

**This ranking of the engineering features/functions/characteristics/metrics** allowed the team to then identify the ones that have the biggest impact on customer requirements. Additionally, the team may identify target values for each metric and indicate whether each feature listed should be present or absent. Achieving each of the targets should mean that the customer(s) will be satisfied with the team's design. **The bottom part of the table is for Benchmarking** or quantifying each competing product/system against engineering features/functions/characteristics/metrics the team developed (*HOW*). If a particular metric or feature doesn't fit with a particular competitor, this may mean the team's list is incomplete. Use appropriate sources. The team may need to make an educated guess and clearly identify that you have guessed. This area allows the team to determine where (measurable) their design needs to be in terms of specifications in moving forward with their selected concept.



# **MODULE 3- ANALYZE**

# Module 3: Overview

---

## Module Objectives

1. **Module Objective 1:** Students will be able to prepare a functional analysis by decomposing key functions required for the engineering design prototype (CLO1)
2. **Module Objective 2:** Students will be able to develop concepts using morphology and sub-function analysis (form and function) (CLO1)
3. **Module Objective 3:** Students will be able to generate feasible concepts using functional analysis and morphological connections (CLO1)
4. **Module Objective 4:** Students will be able to function effectively in selected role (CLO2)
5. **Module Objective 5:** Students will be able to evaluate (give examples of good) teamwork contribution and collaboration (CLO2)
6. **Module Objective 6:** Students will be able to justify own (self) teamwork contribution and collaboration (CLO2, CLO4)
7. **Module Objective 7:** Students will be able to seek assistance for teamwork and conflict resolution (CLO2)
8. **Module Objective 8:** Students will be able to prepare structured summaries of design tool use and results that possess appropriate structure, grammar and tone (CLO3)
9. **Module Objective 9:** Students will be able to explain/communicate the final design concept process to diverse audiences using written and oral presentation methods (CLO3)
10. **Module Objective 10:** Students will be able to apply project management tools to meet deadlines (CLO1)
11. **Module Objective 11:** Students will be able to justify a final design concept proposal by assessing the generated concepts (CLO4)



## Module Highlights

In this module students will review/read content, which includes watching videos. Some videos are quiz-based and/or interactive. The module ends with an industry perspective on the content (Vermeer Co.). There will be activities that will test for understanding of module content. In this module the content will prepare students to work in their design teams to analyze by performing a functional analysis and developing morphology (form). These are key inputs in concept generation. Teams will work to develop 3-4 conceptual ideas by connecting the functional analysis and morphological matrix. The result of this module will be to assess the 3-4 concepts generated in the House of Quality Decision Matrix (HoQ w/DM) to determine the final concept that will become a prototype at the end of the semester. Additionally, students will update their original “draft” project plan to include more defined work that can be distributed based on final design decision form the HoQ. Teams will experience consensus building as they work through the assignments associated with this module, and utilize DMADVR toolbox templates to complete associated assignments.

Teams will complete Peer Review 1. Students will individually complete a peer review to assess team members(s) and self performance regarding teamwork.

Teams can ensure success in this module by completing the team-based assignments, utilizing the DMADVR toolbox templates. Teams need to determine workload allocation, ensure consensus building both in-class and on MS Teams if needed. The key to success is to allocate the workload and follow-up to ensure completion of tasks by team members. This module is critical for the team to develop concepts and assess them to determine the final design the team will work on for the remainder of the semester.



## Materials, Activities and Assignments

- Read/review module content in sequential order per Canvas setup
- Watch embedded videos that contain quizzes and/or interactive activities
- Work through the interactive activities to test your understanding of the content to prepare for team work
- Use associated DMADVR templates as outlined in the assignment document.
- Use CATME to complete Peer Review 1
- Submit assignments by Canvas due dates:

## Functional Analysis and Morph Charts: Concept Generation

This assignment will provide students to maximize their roles/responsibilities in completing the team-based assignments. Teams will work together to generate ideas and analyze functionality needed based on customer requirements. Teams will use the customer needs, engineering specifications, market analysis and benchmarking results as the basis for generating design concepts. The final report section will be completed as an initial draft. This will serve as a foundation in order for teams to select their final design.

This module also provides the opportunity to prepare structured summaries that are an initial draft of the final report.

This assignment will help you to develop...

- **Module Objective 1:** Students will be able to prepare a functional analysis by decomposing key functions required for the engineering design prototype (CLO1)
- **Module Objective 2:** Students will be able to develop concepts using morphology and sub-function analysis (form and function) (CLO1)
- **Module Objective 4:** Students will be able to function effectively in selected role (CLO2)
- **Module Objective 8:** Students will be able to prepare structured summaries of design tool use and results that possess appropriate structure, grammar and tone (CLO3)

### Tasks

The teams will complete tasks as follows:

- Develop/build a function tree and process flowcharts
- Develop functional block diagrams
- Identify inputs/outputs/controls for the flow of energy/matter/information for each function
- Create/develop a morphological chart for each of the lowest level sub-functions in process flowcharts
- Generate 4 complete, feasible concepts from morphological chart. Sketch the concepts and provide a name.

- Complete an initial draft of final report section

## Grading Criteria

The grading rubric is based on the “Expectations of Deliverables” outlined in the assignment document. The rubric is available on Canvas once the assignment is opened.

## Concept Selection Presentation & Design Work Plan

The next step is to evaluate your generated product concepts against the customer requirements and engineering specifications. Based on the results of this evaluation, the team *selects* a final product concept to present/pitch to instructor, TAs, and peers. The QFD with Decision Matrix is used to guide, justify, and document the selection process. The final report section will be completed as an initial draft.

This module also provides the opportunity to prepare structured summaries that are an initial draft of the final report.

This assignment will help you to develop...

- **Module Objective 3:** Students will be able to generate feasible concepts using functional analysis and morphological connections (CLO1)
- **Module Objective 8:** Students will be able to prepare structured summaries of design tool use and results that possess appropriate structure, grammar and tone (CLO3)
- **Module Objective 9:** Students will be able to explain/communicate the final design concept process to diverse audiences using written and oral presentation methods (CLO3)
- **Module Objective 10:** Students will be able to apply project management tools to meet deadlines (CLO1)
- **Module Objective 11:** Students will be able to justify a final design concept proposal by

assessing the generated concepts

## Tasks

The teams will complete tasks as follows:

- Evaluate your product concepts using the QFD w\_DM tab of the DMADVR toolbox:
  - Evaluate your product concepts
  - Select a concept
- Use MS Project to update and finalize the team's work plan and schedule
  - Use the initial project plan as the foundation for updating to create a Final Project Plan
- Prepare and present your work in class via Power point presentation
  - All team member participate (either in person or online)
- Write a final report draft of this section

## Grading Criteria

The grading rubric is based on the “Submission of Deliverables -Expectations” outlined in the assignment document. The rubric is available on Canvas once the assignment is opened.

## Peer Review 1

This assignment will help your learn more about how your peers perceive:

- Contributions to teamwork
- Interaction with Teammates
- Efforts to keep team on Track
- Expectations for quality
- Conflict resolution skills, etc.

This assignment will help you to develop...

- **Module Objective 5:** Students will be able to evaluate (give examples of good) teamwork contribution and collaboration (CLO2)
- **Module Objective 6:** Students will be able to justify own (self) teamwork contribution and collaboration (CLO2)
- **Module Objective 7:** Students will be able to seek assistance for teamwork and conflict resolution (CLO2)

## Tasks

1. Complete a peer review/assessment survey. A link to the survey will be provided in an e-mail to be sent to each student from a system referred to as CATME. It is the student's responsibility to ensure they do not block email from "@CATME.org". Be sure to read and follow the instructions carefully. MUST answer all questions.
2. Please be honest in your responses. It is reasonable that a peer may meet or exceed expectations in several categories but it is unrealistic to rank him or her as exception in every area.
3. Provide written comments describing contributions for each team member and what is working well and not working well for your team. This section is especially important because it is an opportunity for you to be both instructive(teach)and constructive(build)in your evaluation of your team and teammates.

## Grading Criteria

The grading rubric is based on the " Expectations of Deliverables" outlined in the assignment document. The rubric is available on Canvas once the assignment is opened.

# Analyze Phase

---

In this phase, typically the proposed process or product is analyzed and studied to determine whether there are better ways to achieve the desired results. The customer information captured is translated into measurable design performance or function requirements. The requirements can be converted into system, sub-system, and component level design requirements.

A quality function deployment (QFD) tool, the House of Quality (HoQ), is used to translate customer needs into engineering specifications. This phase includes concept development and selection tools such as a function tree, concept form development(morphology), functional analysis, and HoQ. It also includes a final project plan developed to further breakdown the work tasks and timeline (Gantt chart). The Final Design is selected.



# Chapter 1: Introduction to Form (Morphology) in Engineering Concept Generation

---

**In Engineering, function takes the stage before form! It may look “cool” but if it doesn’t function, customers will reject it!**

## Oakley Thump, Oakley (2005)



Sunglasses with a built-in mp3 player (Oakley Thump, 2005). Too expensive (\$495 in 2005 dollars), cheap-feeling, weak sound, and terribly unfashionable.

## Form or Function?

- What if the product form is appealing, yet the form does not function?
- Who would buy them or be impressed by them?
- Would you buy them?
- They look good, but do they perform the way you expect them to?

## Form Follows Function in Product Design

In generating product concepts, the design team **MUST** keep functionality at the forefront!

If a product looks great but doesn’t work, will consumers choose to re-purchase the product after potentially experiencing buyer’s remorse?

Would you re-purchase a product that doesn't work, even if given a refund? How would that change your mind about the product and the company?

*First, what do we want the product to do? Then, how do we want it to look?*

What if the weight of a hotdog model on this vehicle had a dramatic impact on fuel economy?



Oscar Mayer Weinermobile (Image Source: (c) [AirBnb](#))

What if your team's concept design never makes it to the market?



Mazda Furai Concept Car, 2008 (Image Source: [Wikimedia Commons](#))

What if your design team's concept is listed as one of the most beautiful cars by Car and Driver?



2020 Mazda 3 Hatch (Image Source: (c) [Car and Driver](#))

## Conceptual Design

Your design team has worked on understanding the design problem to solve this semester. Your design team:

- Utilized customer input, engineering specifications & benchmarking, along with marketing analysis/information to establish the basis for generating concepts leading to the selection of final design.
- Needs to clearly understand functionality before designing a product's form.

## Concept

**A concept** is an idea that is sufficiently developed to evaluate the physical principles governing the design's behavior. It is necessary to confirm that the concept works and functions per customer needs.

In order to abstract what might someday be a product launched into the marketplace, concepts can be represented using the following methods:

- Rough sketches or flow diagrams

- A proof-of-concept prototype
- A set of calculations or notes

In all cases, functionality **MUST** be ensured.

One or more interactive elements has been excluded from this version of the text. You can view them online here:  
<https://iastate.pressbooks.pub/me270baughman/?p=311#oembed-1>

## [Boat Hulls Designed for Speed Video Script \[DOC\]](#)

### Practice Exercise

An interactive H5P element has been excluded from this version of the text. You can view it online here:  
<https://iastate.pressbooks.pub/me270baughman/?p=311#h5p-71>

## Conceptual design for a toothbrush

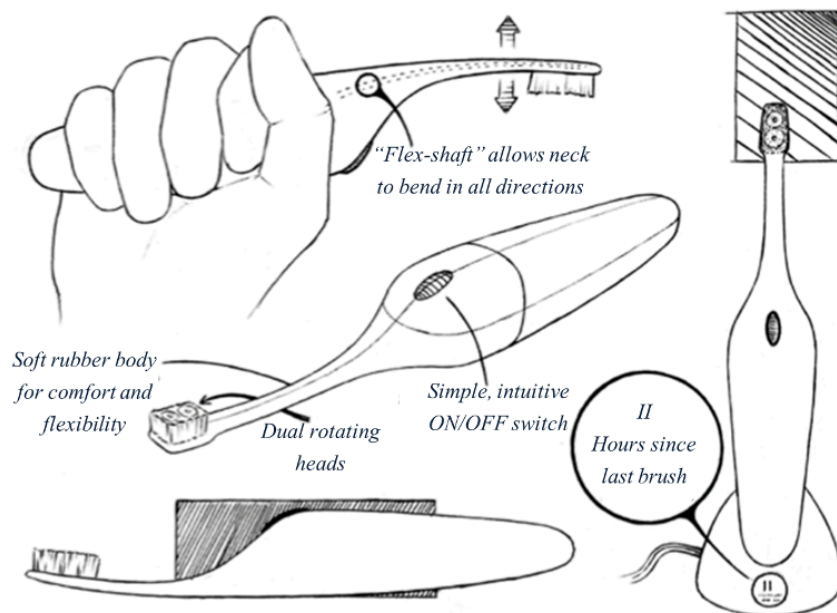

## Practice Exercise

**Concept Development:** Watch the interactive video below and answer the questions that appear.

*An interactive H5P element has been excluded from this version of the text. You can view it online here:*

<https://iastate.pressbooks.pub/me270baughman/?p=311#h5p-60>

# Chapter 2: Functional Analysis and Concept Generation

---

Watch the video below: French Press Coffee Function (No Audio)

One or more interactive elements has been excluded from this version of the text. You can view them online here: <https://iastate.pressbooks.pub/me270baughman/?p=313#oembed-1>

## Function Tree for a French Press

The following represents a function tree with visible functions and hidden sub-functions for the French Press, whose primary function is “Make Coffee.”

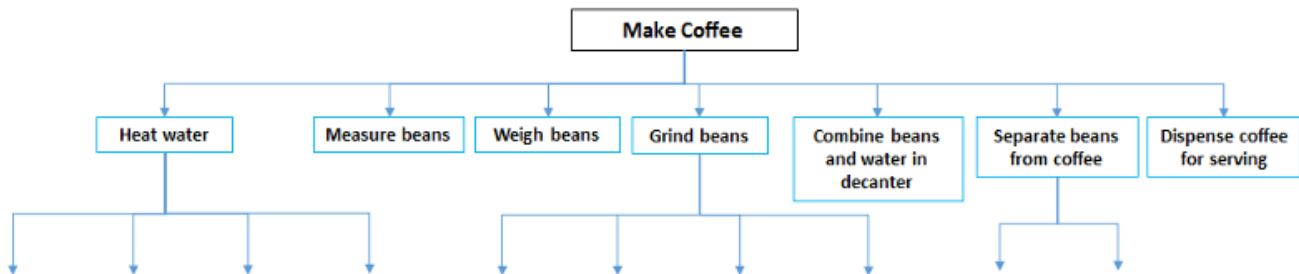

An interactive H5P element has been excluded from this version of the text. You can view it online here: <https://iastate.pressbooks.pub/me270baughman/?p=313#h5p-26>

## Morphology Matrices/Charts











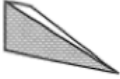

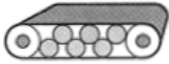

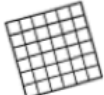

Below is an example of a morphological chart for a vegetable collection system:

- On the left side of the chart, the functions are listed
- On the right side, different mechanisms that can be used to perform the functions listed are drawn
- The chart is a visual aid used to come up with different ideas
- Idea generation is accomplished by creating single systems from different mechanisms

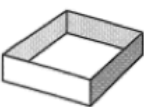
illustrated in the morphological chart.

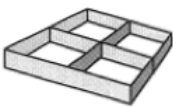









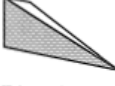

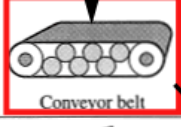



- It is advised to generate several feasible designs using different mechanisms for each function for each concept.

**Example: Vegetable Collection System:**

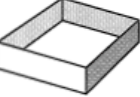
	Option 1	Option 2	Option 3	Option 4
Vegetable picking device		 Triangular plow	 Tubular grabber	 Mechanical picker
Vegetable placing device	 Conveyor belt	 Rake	 Rotating mover	 Force from vegetable accumulation
Dirt sifting device	 Square mesh	 Water from well	 Slits in plow or carrier	
Packaging device				
Method of transportation		 Track system	 Sled	
Power source	Hand pushed	Horse drawn	Wind blown	Pedal driven

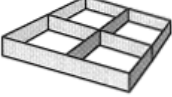
Based on this team's research, the best option for each function was selected: the scoop for picking vegetables, the conveyor belt for placing them, the water from a well for dirt sifting, the bowl for packaging, a track system for transportation, and wind-blown power.

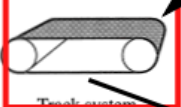
These options are outlined in red on a copy of the morphological chart from above:

	Option 1	Option 2	Option 3	Option 4
Vegetable picking device		 Triangular plow	 Tubular grabber	 Mechanical picker
Vegetable placing device	 Conveyor belt	 Rake	 Rotating mover	 Force from vegetable accumulation
Dirt sifting device	 Square mesh	 Water from well	 Slits in plow or carrier	
Packaging device				
Method of transportation		 Track system	 Sled	
Power source	Hand pushed	Horse drawn	Wind blown	Pedal driven

Concept 1

Concept 1 utilizes the morphology of the best options identified by the team.

### Concept 1: Vegetable Collection System

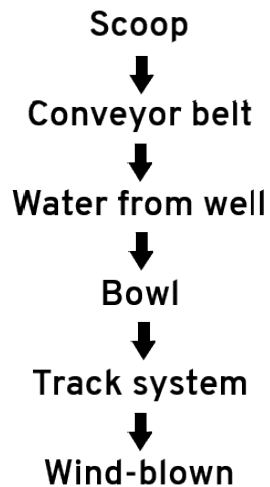



Concept 1 is represented in order through the image above.

In product design, there are two templates used to develop morphology:

1. A **matrix** is as outlined in the video, and
2. a **morphological chart** is as shown above.

The morphological chart provides visual representations of functions that need to be achieved, and select concepts to be brought forward for further analysis. We will be utilizing the morphological chart in ME 270.

## Practice Exercises

*An interactive H5P element has been excluded from this version of the text. You can view it online here:*

<https://iastate.pressbooks.pub/me270baughman/?p=313#h5p-28>

*An interactive H5P element has been excluded from this version of the text. You can view it online here:*

<https://iastate.pressbooks.pub/me270baughman/?p=313#h5p-29>

# Chapter 3: QFD (House of Quality w/Decision Matrix) - HoQ w/DM

---

## Introduction

Your team developed an expansive list of design solution concepts for basic product functions identified using function trees/functional decomposition and morphology.



## Next steps

Use House of Quality (QFD) with Decision Matrix to guide, justify, and document your decision in final concept selection:

1. **Identify** and select a full product concept to take into the detailed design;
2. **Synthesize** the basic function of generated concepts;
3. **Evaluate** concepts against engineering metrics and features (and thus the customer requirements);
4. **Select** a product concept to take into detailed design.

## Evaluating Generated Concepts: How to pick the best option

- Utilize the House of Quality Decision Matrix – Engineering Specifications: features, functions, and characteristics, directly linked to Customer Requirements.
- Evaluate only your top 3-4 concepts (review assignment requirements).

## MIRE TECH Team Final Stove: An Example

Let's take a look at MIRE TECH's Functional Analysis and Morphological Charts/Matrices in generating their final stove design.

The team used **Functional Analysis** to determine which functions are critical for the stove to achieve the main functionality.

The **functional analysis of the hex stove** is a model that follows energy, more specifically heat, from the inputs to the outputs of the system. It is a very broad overview of the path the energy takes through the system but is expanded upon in greater detail in the mathematical model. The math model accounts for all energy changes and transfers while the functional analysis ignores all losses for simplification.

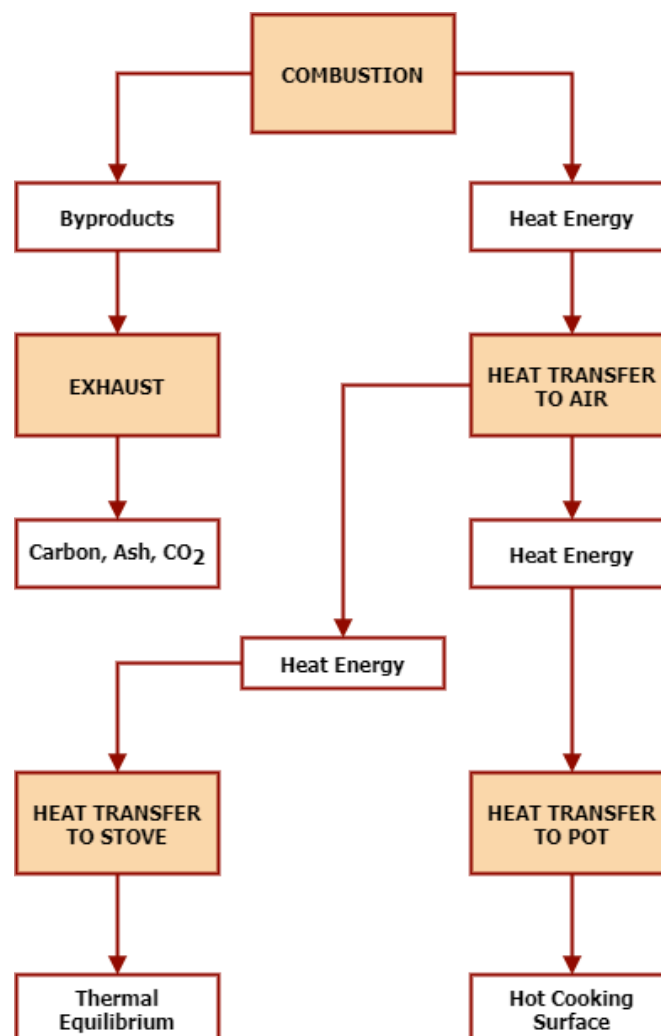

Based on the team’s morphological charts, the top 4 designs below (Concept Selection) were brought forward:

CONCEPT SELECTION:

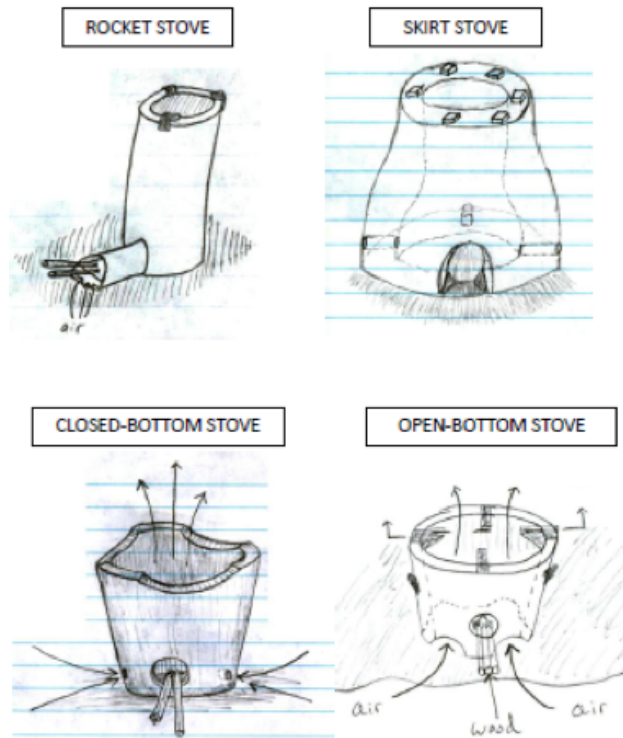

Stove concepts for selection – Concept 1 morphology. Options include a rocket stove, skirt stove, closed-bottom stove, and an open-bottom stove.

## Example Exercise

Watch the interactive video below and answer the questions: HoQ w/Decision Matrix

An interactive H5P element has been excluded from this version of the text. You can view it online here:

<https://iastate.pressbooks.pub/me270baughman/?p=315#h5p-61>

[House of Quality with Decision matrix Video Script \[PDF\]](#)





This House of Quality with Decision Matrix shows the Now vs. What. The Now area is the current products on the market that the engineering design team has researched. The What area is what the team concepts are for solving the design need. The numbers are how both the Now products on the market and the engineering design team's concept assessments based on the customer requirement assessment of 1, 3, 9. How does the team know which of their concepts is the top one or the design they are most likely to select? Well, the highest scorer is the one they need to consider as the recommended final design, and this would be the score of 2277 for the Lightning Bug Design. You can also see this in the image below. The Firefly's design team's final concept assessment indicates the Lightning Bug is the design they will move forward with based on an objective high score. The scoring removes subjectivity as much as possible in order to allow the team to make an objective decision based on their assessment analysis. However if the the top 2-3 designs scored within 10% of each other, the team should consider reviewing their assessment and to determine if re-scoring is needed. Another option is for teams to consider combining the best elements and then re-score to determine the best design choice with the highest score.

See below a cut-out image of the final scoring assessment where the team has scored The Lightning Bug as the final design. This decision was based on the highest score!

**Reminder:** In ME 270, only use 1, 3, 9 values are used to assess within the House of Quality (HoQ/QFD). This Firefly Team example deviates from this but it is an illustration of the process of completing a HoQ.

## Firefly Team’s Concept Assessment:

4. Now									
Solar Tulkis	Crackled Globe Light	Exponent® Flashlight & Collapsible Lantern	Sun Jar	Goals	Lighting Bug	Double Reflection	Light Reject	Light-O-Lantern	
5. Now vs. What									
3	3	5	2	5	4	5	4	5	5
2	5	5	4	5	4	5	3	3	3
1	4	2	5	5	5	3	5	3	3
3	5	1	5	5	5	3	4	3	3
2	2	1	3	3	4	3	4	3	3
5	3	5	3	5	4	4	4	4	4
3	5	4	5	5	5	5	5	5	5
5	2	5	2	5	5	4	4	4	4
3	1	5	1	5	4	5	4	5	5
1596	1647	1861	1637		2277	2091	2104	2017	

Click on the image to enlarge and review

An interactive H5P element has been excluded from this version of the text. You can view it online here:  
<https://iastate.pressbooks.pub/me270baughman/?p=315#h5p-30>



# Chapter 4: Final Project Plan and Concept Presentation

## 1. Teams develops a final project plan!

- Update the initial project plan developed and submitted with the Project Charter using MS Project!
- The final project plan will reflect more of the team’s roles and allocation of team resources to design, build, test, and report out regarding the team’s prototype.

### Example from DMADVR Toolbox for team review

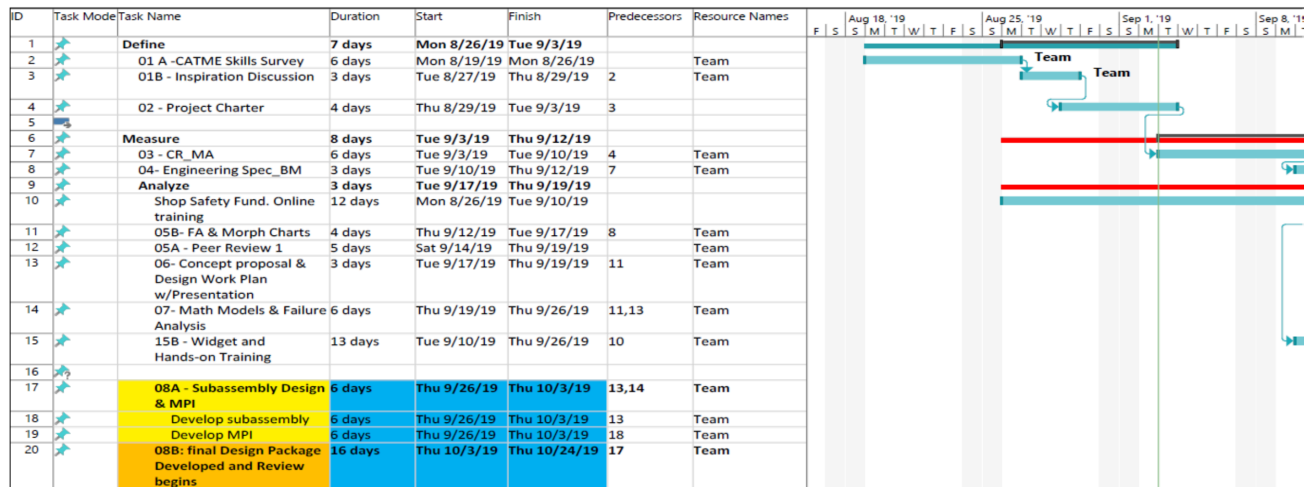

Click on the project plan example to enlarge and review the image.

This project plan image is an example from MS Project 2019. As MS Project progresses to the next version, students will need to populate the columns and rows as per that version. A video providing information on modifications or changes due to the newest version of MS Project Professional provided by ISU that impacts the course will be posted by the instructor.

The final project plan will be updated based on the results from the Concept Review. The details can be added based on work tasks that need to be added and/or more specific detail

added in order to complete the design project on time. The detail in the ID columns 18 and 19 are based on detailed tasks that need to be completed in order for Assignment 08A to be complete and the timeline adjusted to ensure that the tasks are completed on time. These lower-level tasks are indented to the right to indicate that they are associated with the main Assignment 08A to indicate a rollup to this larger task.

*An interactive H5P element has been excluded from this version of the text. You can view it online here:*

<https://iastate.pressbooks.pub/me270baughman/?p=1064#h5p-72>

## 2. Teams develop a presentation for “Concept Review”

- Review assignment for content requirements! All Teams present! All Team members participate!

**Watch the comedic video below!**

*One or more interactive elements has been excluded from this version of the text. You can view them online here:*

<https://iastate.pressbooks.pub/me270baughman/?p=1064#oembed-1>

[Death by PowerPoint Video Script \[DOC\]](#)

# **MODULE 4A - DESIGN**

# Module 4A: Overview

---

## Module Objectives

1. **Module Objective 1:** Students will be able to create a math model representing the engineering design functionality (CLO1)
2. **Module Objective 2:** Students will be able to perform a design failure modes and effects analysis (DFMEA) on the engineering design prototype (CLO1)
3. **Module Objective 3:** Students will be able to prepare engineering drawings using engineering graphics/CAD software for the final design (CLO1, CLO2)
4. **Module Objective 4:** Students will identify the appropriate manufacturing/assembly processes for building a functional prototype (CLO1)
5. **Module Objective 5:** Students will identify/locate locally sourced materials to use in the final engineering design prototype (CLO4)
6. **Module Objective 6:** Students will be able to prepare structured summaries of design tool use and results that possess appropriate structure, grammar and tone (CLO3)
7. **Module Objective 8:** Students will prepare a product cost calculation using a bill of materials and within budgetary constraints for the prototype (CLO1)



## Module Highlights

In this module, students will review/read the content, including watching videos. Students will watch quiz-based/activity-based videos and complete test for understanding activities. This will prepare students for the teamwork activities of completing a design risk assessment (DFMEA), set of drawings with bill of materials (BOM) for one sub-assembly, and associated manufacturing process instructions (MPIs). The selected sub-assembly will be reviewed by manufacturing (Boyd Lab), and teams will make necessary updates to obtain design manufacturability approval from Boyd Lab. Students will work in their teams and arrange

work in accordance with the workplace based on roles/responsibilities in allocation of work to complete assignment.

## Materials, Activities and Assignments

- Read/review module content in sequential order as setup in Canvas
- Watch embedded and associated module videos
- Discuss in-class and on MS Teams the work progress to ensure work is completed and submitted per Canvas due date
- Utilize Canvas templates to complete work as outlined in assignment document
- Utilize Solidworks to complete CAD work as outlined in assignment document
- Consult and work with Boyd Lab regarding design and part/components for sub-assembly and related manufacturing process to obtain approval for sub-assembly design
- Submit module assignment(s):

### Math modeling and failure analysis

Student teams will use analysis skills to create an engineering math model, brainstorm possible failure modes for your design, and plan for future actions to eliminate failure modes. The team will also develop a draft of the final report for this section.

In order to successfully complete this assignment , teams will need to allocate work, considering roles/responsibilities. This interaction may take place in the classroom and on Microsoft Teams. The team will complete the DMADVR toolbox template(s) and submit it to Canvas. This assignment will require teams to work together to get the major tasks completed.

This activity will help you to develop...

- **Module Objective 1:** Students will be able to create a math model representing the engineering design functionality (CLO1)
- **Module Objective 2:** Students will be able to perform a design failure modes and effects analysis (DFMEA) on the engineering design prototype (CLO1)
- **Module Objective 6:** Students will be able to prepare structured summaries of design tool

use and results that possess appropriate structure, grammar and tone (CLO3)

## Task

Teams will have a refined/completed math model, completed QFD(House of Quality), completed DFMEA and draft report of this section for your final report. Teams need to analyze how the selected product concept will actually meet the specifications and avoid serious failures. Constructing a mathematical model allows the team to assess the concept's ability to meet the specifications. The math model casts product functions as mathematical relationships between inputs, outputs, and control variables. The team will utilize a Design Failure Modes Effect Analysis (DFMEA) to (i) identify potential failure modes in the design and (ii) reduce or eliminate their likelihood of impact on performance, reliability or safety through planned action. Lastly, you will complete or modify section 8 (Engineering Specifications and Benchmarking) and section 9 (the roof) in your QFD. Teams will write a draft of this section of your final report on the modeling process and failure analysis.

## Grading Criteria

Grading is based on the "Submission Deliverables Expectations" outlined in the assignment document. This is reflected in the grading rubric available to students on the Canvas once the assignment is opened.

## Sub-assembly Design Package Review

Student teams will utilize their roles/responsibilities in this assignment to prepare a set of engineering drawings and manufacturing instructions for one sub assembly. The bill of materials (BOM) will be drafted, and analytical skills will be utilized to prepare an initial total prototype cost.

In order to successfully complete this assignment, the teams must interact/discuss both in-class and on MS Teams (if needed) the roles/responsibilities that will lead to workload allocation in this assignment. This assignment relies heavily on allocation tasks in order for teams to come work on individual tasks, and come together to complete and submit the assignment. CAD skills are a key success factor, as are analytical and writing skills. Teams will need to select a subassembly strategically, and this will be a consensus building activity. The Boyd Lab and the instructor are resources for teams to discuss their subassembly determination. The strategic decision will impact the team's work tasks regarding the entire prototype design, assembly/manufacturing, cost, and testing plan. Student teams will be utilize all appropriate DMADVR toolbox templates to completed work.

This activity will help you to develop...

- **Module Objective 3:** Students will be able to prepare engineering drawings using engineering graphics/CAD software for the final design (CLO1, CLO2)
- **Module Objective 4:** Students will identify the appropriate manufacturing/assembly processes for building a functional prototype (CLO1)
- **Module Objective 5:** Students will identify/locate locally sourced materials to use in the final engineering design prototype (CLO4)
- **Module Objective 6:** Students will be able to prepare structured summaries of design tool use and results that possess appropriate structure, grammar and tone (CLO3)
- **Module Objective 8:** Students will prepare a product cost calculation using a bill of materials and within budgetary constraints for the prototype (CLO1)

## Task

Teams will design a subassembly design package for review by the Boyd Lab (manufacturing) to obtain approval of it's manufacturability. Teams will produce a simple CAD or hand sketch of the prototype to ensure sizing requirements of the assignment are met (will fit entirely in the team's storage tote at all stages of the class, and can be placed in the tote unassembled at the end of each class period). No other storage is available. This will be an important step in moving towards approval of the final prototype. A completed and approved set of CAD drawings will be produced for ONE subassembly. A completed initial draft of the entire prototype's bill of materials (BOM) with all parts accounted for that are known at the time. Bill of materials will be used as input into the initial Purchase Order draft to be reviewed by Boyd Lab and/or instructor to include parts/components only from the approved vendor list. All costs must be within the

budget as outlined in the assignment document. A draft of this section of the final report will be produced. The DMADVR toolbox templates that are outlined in the assignment document will be completed by the teams.

## Grading Criteria

Grading is based on the “Submission Deliverables Expectations” outlined in the assignment document. This is reflected in the grading rubric available to students on the Canvas once the assignment is opened.



# Design Phase

---

## Begin detailed design work for selected Final Design

### This includes:

- math modeling
- risk assessment & mitigation (DFMEA -design failure mode & effects analysis)
- bill of materials (BOM),
- purchase order,
- part cost determination
- profit/loss (P/L) statement
- mfg process instructions (MPIs)
- both a sub-assembly
- final product design (Solidworks) approval process resulting in a final engineering design package submittal
- final prototype design is manufactured/built/assembled
- may also result in ECNs (engineering change notices) as a result of the manufacturing/build/assembly process prior to testing

## Definition of a prototype

- An original model on which something is patterned; archetype.
- An individual that exhibits the essential features of a later type.
- A standard or typical example.
- A first full-scale and usually functional form of a new type or design of a construction.

## Your team's prototyping goal

Build/manufacture/assemble a team-designed “functional” device, and test essential performance measures of the product design.

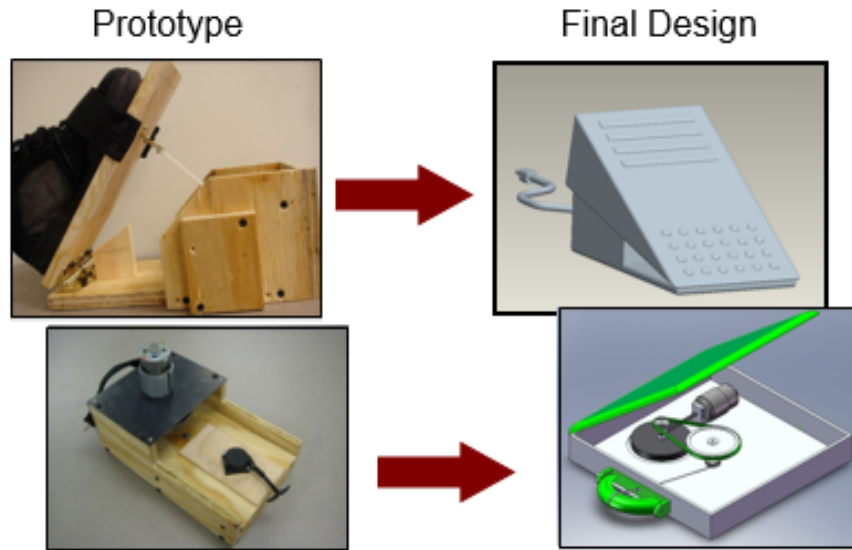

### Why build a prototype?

1. **Conceptualization:** Demonstrate feasibility/practicality.
2. **Verification and Testing:** Verify performance modeling. Prove/disprove assumptions made.
3. **Development – Refine the Design:** Identify design deficiencies/improvement. Suggest a mass manufacturing process.

**Table. Prototype Constraints**

Time	Cost	Materials	Tools/Process	Personnel	Tote Sizes
<ul style="list-style-type: none"> <li>• Planning: 1.5 weeks</li> <li>• Fabrication: 2.5 weeks</li> <li>• Testing: 1 week</li> </ul>	<ul style="list-style-type: none"> <li>• \$85 if purchased</li> <li>• \$50 if donated</li> </ul>	<ul style="list-style-type: none"> <li>• Stock from shop</li> <li>• Approved vendors (See Boyd Lab)</li> <li>• Grainger, McMaster, typically</li> </ul>	<ul style="list-style-type: none"> <li>• Boyd Lab only (Requires training)</li> </ul>	<ul style="list-style-type: none"> <li>• Team members</li> </ul>	<ul style="list-style-type: none"> <li>• Width x Depth x Height (Measure for yourself)</li> </ul>

# Chapter 1: Modeling

---

## Modeling

Now that your design team has selected a product concept:

- Developed a function tree tree, and ensured sub-functions are broken down via a function block diagram
- Continue work from functional analysis to develop a math model to accomplish these functions

**Watch the interactive video below: Math Models- Basic Part 1**

An interactive H5P element has been excluded from this version of the text. You can view it online here:

<https://iastate.pressbooks.pub/me270baughman/?p=678#h5p-63>

Your design team will assess the ability of your selected concept to meet the specifications by constructing a *mathematical model* that casts product functions as mathematical relationships between inputs, outputs, and control variables.

## Math Modeling

**Watch the interactive video below: Math Model-Basic Part 2**

An interactive H5P element has been excluded from this version of the text. You can view it online here:

<https://iastate.pressbooks.pub/me270baughman/?p=678#h5p-62>

**Practice Exercise**

Use the figure below and text your understanding with the french coffee press:

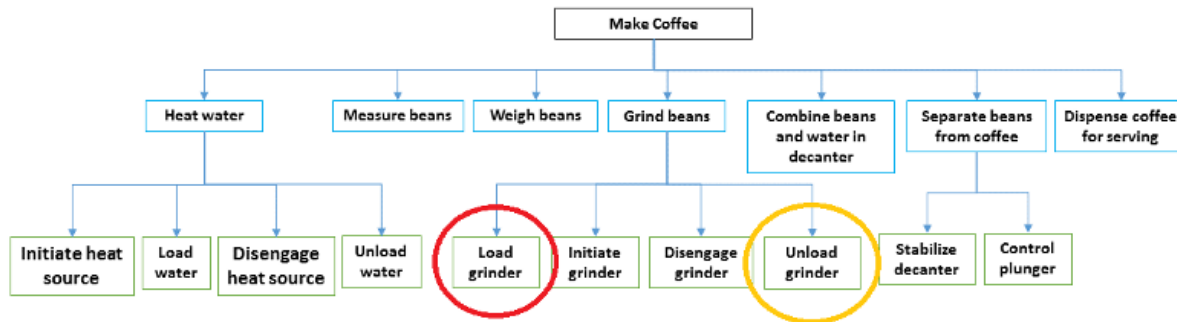

An interactive H5P element has been excluded from this version of the text. You can view it online here:

<https://iastate.pressbooks.pub/me270baughman/?p=678#h5p-31>

## Example Math Modeling: ME 270 Seeder Project

Click here to view and download the template of the [System Model Final Concept Process Flow with math model\(Arens\) example in DMADVR Toolbox \[XLS\]](#)

The downloadable excel sheet is from the DMADVR Toolbox Template for System Modeling. The left side shows the process flow for the team's final selected design. It indicates the Inputs, Outputs, and controls the process flow for the functions of the Seeder. The boxes indicate the function with their inputs, outputs, and controls. Once these are identified the math modeling can be developed. The colored boxes (yellow, green, and purple) show the variables, values, and units for the Inputs, outputs, and controls. The box in the upper right corner identifies the variables, provides a description and identifies the units used. The functions in the process flowchart are used to determine the conversion equations (and thus the variables) associated with the functionality needed. The equations are shown to the right of the colored boxes. The conversion equations can be used to predict performance and verify this during the testing process. Also in this System Model template, the sources for equations and information need to be cited at the bottom of the Model as shown here.



decisions on the Trade-offs! This form is in the DMADV Toolbox, and is part of the HoQ(the roof!).

# Chapter 2: Design Failure Mode & Effects Analysis (DFMEA)

---

## Headlines on Product Failures:

### XBOX 360



“Microsoft said Thursday that it will take a \$1 billion charge as it extends the warranty on the Xbox 360, after an investigation showed the game console can be prone to hardware failures. ‘As a result of what Microsoft views as an unacceptable number of repairs to Xbox 360 consoles, the company conducted extensive investigations into potential sources of general hardware failures,’ Microsoft said in a statement.”<sup>1</sup>

---

1. Fried, I. 2007. "Microsoft to extend Xbox 360 warranty, take \$1 billion hit." *CNET*. <https://www.cnet.com/tech/tech-industry/microsoft-to-extend-xbox-360-warranty-take-1-billion-hit/>

## FitBit Force, FitBit (2014)



This version of the activity-tracking device was causing skin irritation and even blisters so severe that it resulted in a class-action lawsuit in California.<sup>2</sup>

## Galaxy Note 7, Samsung (2016)



Launched in August of 2016, the Note 7 boasted powerful hardware and had consumers chomping at the bit to get their hands on them. The anticipation quickly faded, though, as reports of Note 7s catching fire started hitting the news.

---

2. CB Insights. 2021. "When Corporate Innovation Goes Bad — The 164 Biggest Product Failures Of All Time." <https://www.cbinsights.com/research/corporate-innovation-product-fails/>



By September 2, Samsung had stopped sales of the device. Next came a formal recall in the US on September 15th and a worldwide recall on October 10th. The product was completely abandoned on October 11th.<sup>3</sup>

## Watch the Interactive Video: DFMEA 1

*An interactive H5P element has been excluded from this version of the text. You can view it online here:*

<https://iastate.pressbooks.pub/me270baughman/?p=680#h5p-64>

## Watch the Interactive Video: DFMEA 2

*An interactive H5P element has been excluded from this version of the text. You can view it online here:*

<https://iastate.pressbooks.pub/me270baughman/?p=680#h5p-65>

*An interactive H5P element has been excluded from this version of the text. You can view it online here:*

<https://iastate.pressbooks.pub/me270baughman/?p=680#h5p-51>

## Watch the Video: DFMEA Step-by-Step Example

*One or more interactive elements has been excluded from this version of the text. You can view them online here:*

<https://iastate.pressbooks.pub/me270baughman/?p=680#oembed-1>

[DFMEA Example 1-Video Script \[DOC\]](#)

---

3. Fisk, P. 2020. "Innovation Failures of the 21st Century ... Amazon Fire and Google Allo, Mercedes Home Battery and Nike FuelBand ... without failure, we don't learn how to be better." <https://www.peterfisk.com/2020/06/innovation-failures-of-the-21st-century-amazon-fire-and-google-allo-mercedes-home-battery-and-nike-fuelband-without-failure-we-dont-learn-how-to-be-better/>

## Ball Point Pen DFMEA EXAMPLE:

Product Name/Description: Ball Point Pen (PT1302-405) Model: Handline-PS, Year 2019		Prepared by: Team (Responsible: Drinnwood Dawson, Katie Saul, Lou Woodard, Alex Yi)		Page: 1 of 1											
DFMEA Date (Orig): 09/03/2019 (Rev): 09/03/2019															
Item	Function	Potential Failure Mode	Potential Failure Effects	S E V	Root Cause	O C C	Current Design Controls (Prevention/Detection)	D E T	R P N	Actions Recommended	Responsibility & Target Completion Date	Actions Taken & Effective Date	S E V	O C C	R P N
What is the assembly/subsystem being analyzed?	What is the function of the sub-assembly/part being analyzed?	Identify the potential failure mode(s) associated with the function(s)?	What is the impact to the Customer?	How severe is the failure mode?	Identify all potential causes of the failure mode?	How often does the failure mode occur?	What are the tests, methods or techniques to discover the root cause before design release?	How often will the failure mode occur?	What are the actions for reducing the occurrence of the Cause, or improving detection? Should have actions only on high RPN's.	Whose Responsible for the recommended action? What is the target completion date?	What are the completed actions taken in order to re-validate the RPN? Be sure to include completion month/year				
Pen Tip	Dispenses proper ink amount onto paper	Not enough ink	Pen skip or required heavy pressure while writing	7	Ball diameter is too big	6	Writing test to detect if problem occurs	3	26	Katie, Nov. 24	Writing Test with varying pen angles of the pen. Katie, Nov. 24	7	3	2	42
					Narrow pen angle when writing	4	Writing test with minimum pressure on the paper	2	56						
	Too much ink	Globs or drip left behind the letters	7	Ball diameter is too small	3	Writing test to detect if problem occurs	3	63	Katie, Nov. 24	Writing Test with varying pen angles of the pen. Katie, Nov. 24	7	3	2	42	
				Pressure of user on the pen too much	3	Writing test with high pressure	3	63							
The ball runs smoothly	Not smoothly	Inconsistent line skip or glob left behind	8	Improper selection of dimension of the ball and ball socket	4	Writing test with minimum pressure on the paper	2	64	Katie, Nov. 24	Writing Test with varying pen angles of the pen. Katie, Nov. 24	7	3	2	42	
				Improper selection of the ball roughness tolerance	2	Select surface roughness base on the standard	3	48							

Ballpoint pen DFMEA example picture image. Click this link to view the full-size Ballpoint pen DFMEA example in the DMADVR Toolbox

Click on the links below to find two examples of math modeling and DFMEA documentation for both the MIRE TECH and Cassava Grinder ME 270 design teams:

- [MIRE TECH math model and DFMEA EXAMPLE \[PDF\]](#)
- [cassava math model EXAMPLE \[PDF\]](#)

**CAUTION: DFMEA template in the DMADVR Toolbox is slightly different but the process is the same! Read the assignment and follow the DMADVR Toolbox template!**

## DFMEA\_Seeder Example

Product Name: G.I.M.		Prepared by: Swick		Page 1 of 1												
Responsibility: Swick		DFMEA Date (Orig): 2/11/2020 (Rev):														
System, subsystem, or Part Description	System, Subsystem, or Part Function	Potential Failure Mode	Potential Failure Effects	S E V	Root Cause	O C C	Current Design Evaluation or Control	D E T	R P N	Actions Recommended	Resp.	Actions Taken	S E V	O C C	R P N	
What is the system, subsystem or part under evaluation?	What is the Function Provided by the system, subsystem or part?	In what ways does this function lose its functionality?	What is the impact to the Customer?	How severe is the failure mode?	What root cause of the loss of function?	How often does the failure mode occur?	What are the tests, methods or techniques to discover the root cause before design release?	How often will the failure mode occur?	What are the actions for reducing the occurrence of the Cause, or improving detection? Should have actions only on high RPN's or easy fixes.	Whose Responsible for the recommended action?	What are the completed actions taken with the recommended RPN? Be sure to include completion month/year					
Bag outlet	Cuts bag open	Can't cut bag	Can't cut bag	2	Dull blade	6	Fatigue testing	3	36				2	6	3	36
Handle	Full planter, adjust height	Can't pull	Can't pull planter	8	Handle breaks	3	Pull on the handle with a lot of force to see if it breaks	1	24				8	3	1	24
Flow	To place the ground in front of the planter in order for planting	Can't flow	Can't plow	6	Flow breaks	3	Performance test	1	18				6	3	1	18
		Can't flow	Can't plow	3	Flow dulls	3	Material test	3	27				3	3	3	27
Seal	To keep the seeds from spilling out of the planter	Spew Spills	Loss of seed and planting	8	Seal loosens	3	Material test	6	144	Test durability with respect to fatigue loosening	Swick	Changed materials to P.U.C. in order to increase durability and consistency.	8	2	6	96
Planting wheel	To plant 3-7 seeds per hole and correct spacing apart	Doesn't plant correct amount	Seed overflow or jam	8	Seed build up and jam	3	Efficiency test	1	24				8	3	1	24
Axle	Rotate wheels	Can't plant	Wheel isn't aligned	9	Warping	3	Material test	4	96				8	3	4	96
Hopper	Holds seed	Can't plant	Hopper jams	8	Seed build up	8	Efficiency test	1	64				8	8	1	64
Back plate	To cover the hole with the soil pressed out	Can't cover hole	Rate breaks	6	Too much force is exerted	3	Performance test	3	54				6	3	3	54

Click this image to view the full-size Seeder DFMEA from the DMADVR Toolbox image

# Chapter 3: Engineering Drawings and MPIs

---

## Subassembly & MPIs

*An interactive H5P element has been excluded from this version of the text. You can view it online here:*

<https://iastate.pressbooks.pub/me270baughman/?p=717#h5p-66>

## The Process for Assigning Part Numbers

- Assemblies start with AN
- Parts start with N
- Part numbers are not Item numbers (balloon callouts)
- Part numbers are not Part descriptions

## Part Tree: An Example of Part Number Hierarchy

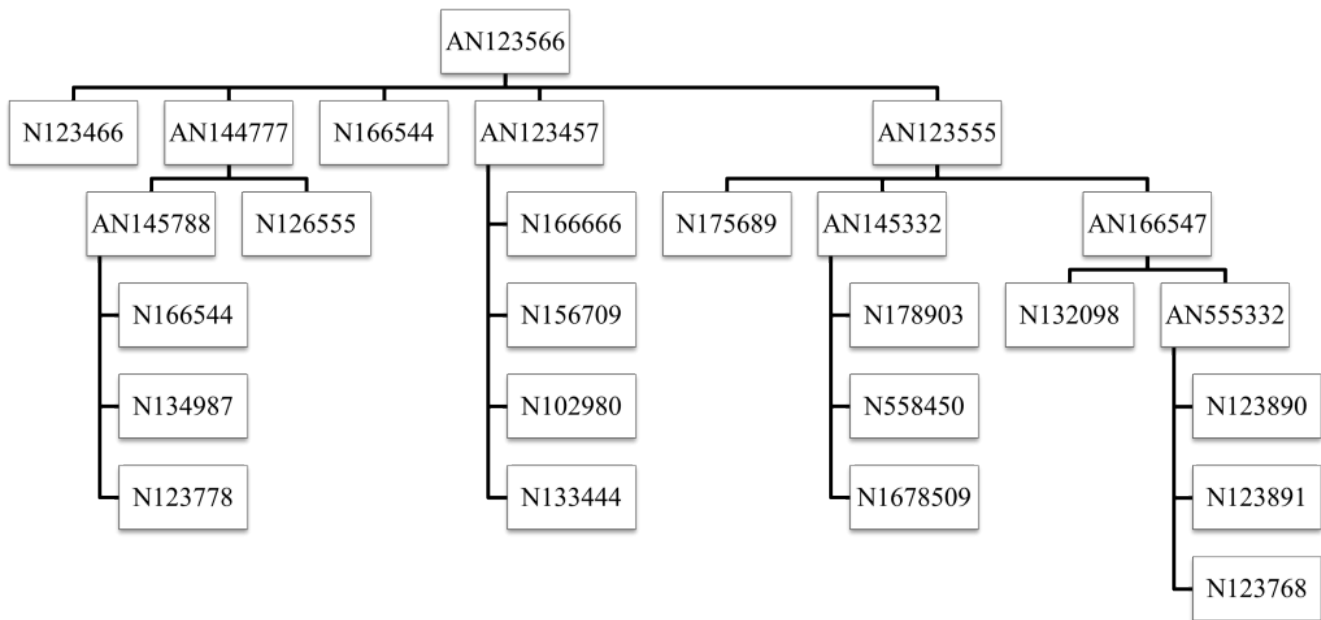

This image of the ME 270 Part Hierarchy starts with the prototype part number as the top box and resembles an organizational chart. The top box is the prototype part number and it flows down into the individual part numbers (starts with N) and sub-assemblies/ assemblies (start with AN). Typically the sub-assemblies/assemblies will flow down to incorporate more assemblies and also parts that makeup assemblies. The lowest levels are part numbers. Click on the image to view or download.

## Engineering Drawing Guidelines for ME 170 and 270

Definition of an engineering drawing:

- A formal and precise way of communicating information about the shape, size, features, and precision of the item to be manufactured.
- Drawings are the universal language of engineering.
- Working drawings serve as a guide for the manufacture and assembly of your prototype

### Installation of Solidworks Templates:

1. Place this file at root directory of U: drive [SOLIDWORKS.zip \(External link\)](#)
2. Right click to extract files to U: drive root directory and place as shown below. It must be

exactly at U:\\_SOLIDWORKS\\_Solidworks\_Templates.

## Settings in Solidworks

Solidworks needs to have some settings made. One of the parameters locates the above templates for Solidworks.

- If you are on an ISU computer, right click “swSettings.sldreg” to “Create Shortcut” on the desktop. Then double click the shortcut each time before running Solidworks. Because ISU uses floating profiles, the information contained in the swSettings.sldreg disappears when one logs off an ISU computer. Each time you login, you must double click the icon and accept the default settings.
- If on your own personal computer, double click “swSettings.sldreg” and accept the default settings. This sets your PC defaults and will not need to be repeated.

## Getting Solidworks on Your PC

1. [VDI \(Virtual Desktop Interface\)](#). is the only way to go for a Mac user and for many PC users.
2. [Solidworks Install \(Get Latest Version Available\)](#).
3. [Home Directories \(aka the U: drive\)](#). should be used to store your homework and the templates for Solidworks. Files are securely stored with backups and revision tracking. If your computer crashes, your homework won't be lost.

## Off-campus Access

**If you run Solidworks outside the ISU network**, you must gain access to the network for Solidworks licensing (and home files). Use [the Iowa State VPN \(Virtual Private Network\)](#) before starting Solidworks or VDI. VPN is also required for Home Directories (U: drive) if off campus.

## Drawing Standards

- ANSI/ ASME Y14.1 – Y14.100 standards (Third Angle of Projection).
- ANSI/ ASME Y14.5 standard covers dimensioning and tolerancing rules.

- The ANSI/ ASME standards, conventions, and guidelines must be applied to read/create a proper working drawing.

## Basic Information

- Projected Views show as many sides as needed for completeness.
- Cross Sections for showing interior features.
- Dimensions and tolerances which are the most important and most complicated part of the drawing.
- Titleblock at the lower right corner, with material information, part name, designer, etc.

## Examples:

### Sub Assembly: Exploded and Assembled Drawings

**Exploded View↓ & Balloons↓**

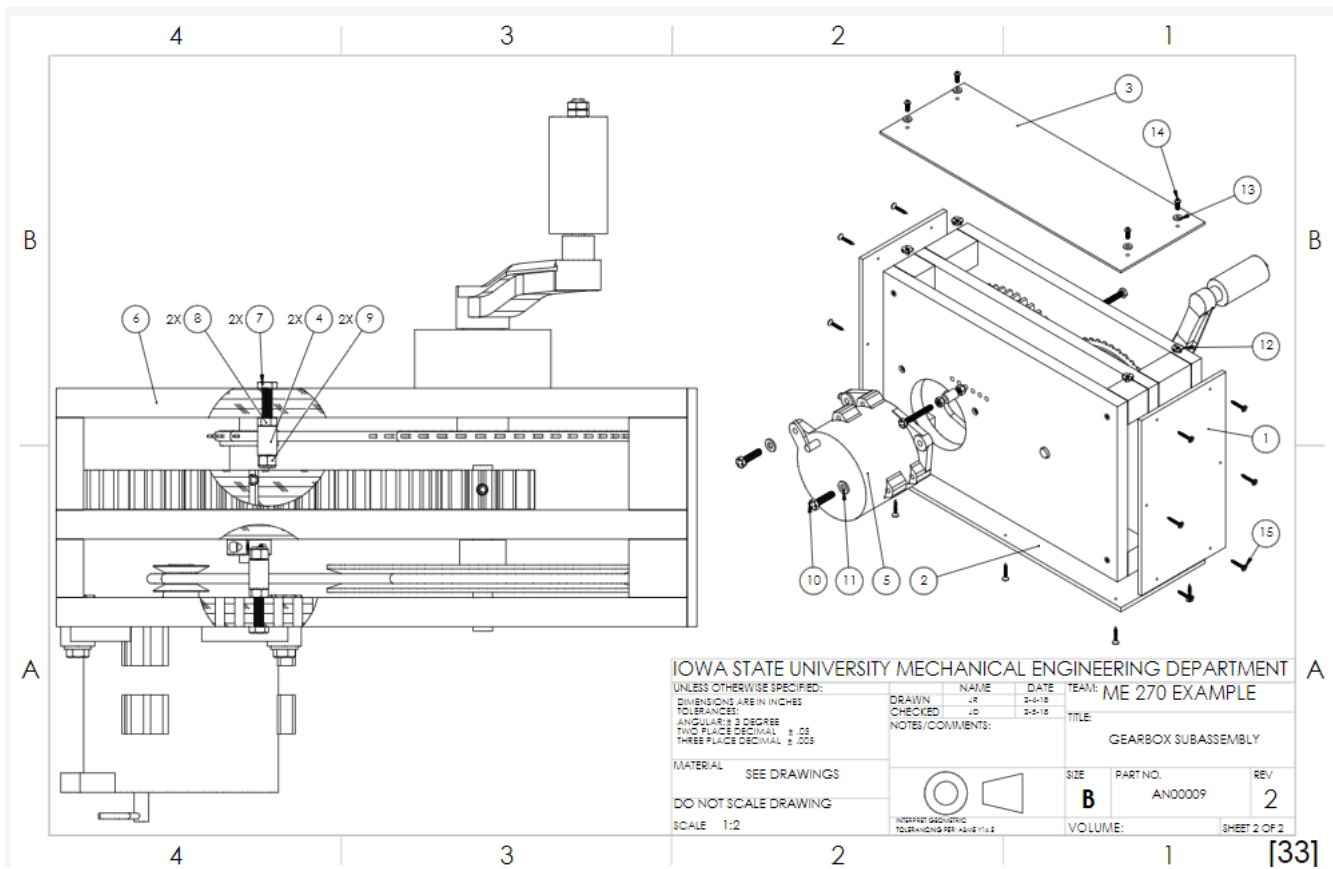

This picture/image is a engineering drawing example of a gearbox subassembly. It shows an exploded view, numbered part balloons, and sectioning. It also includes the title block in lower right corner of the drawing. Click on picture/image to review and/or download.

**Assembled view** ↓

**Parts list (BOM)** ↓

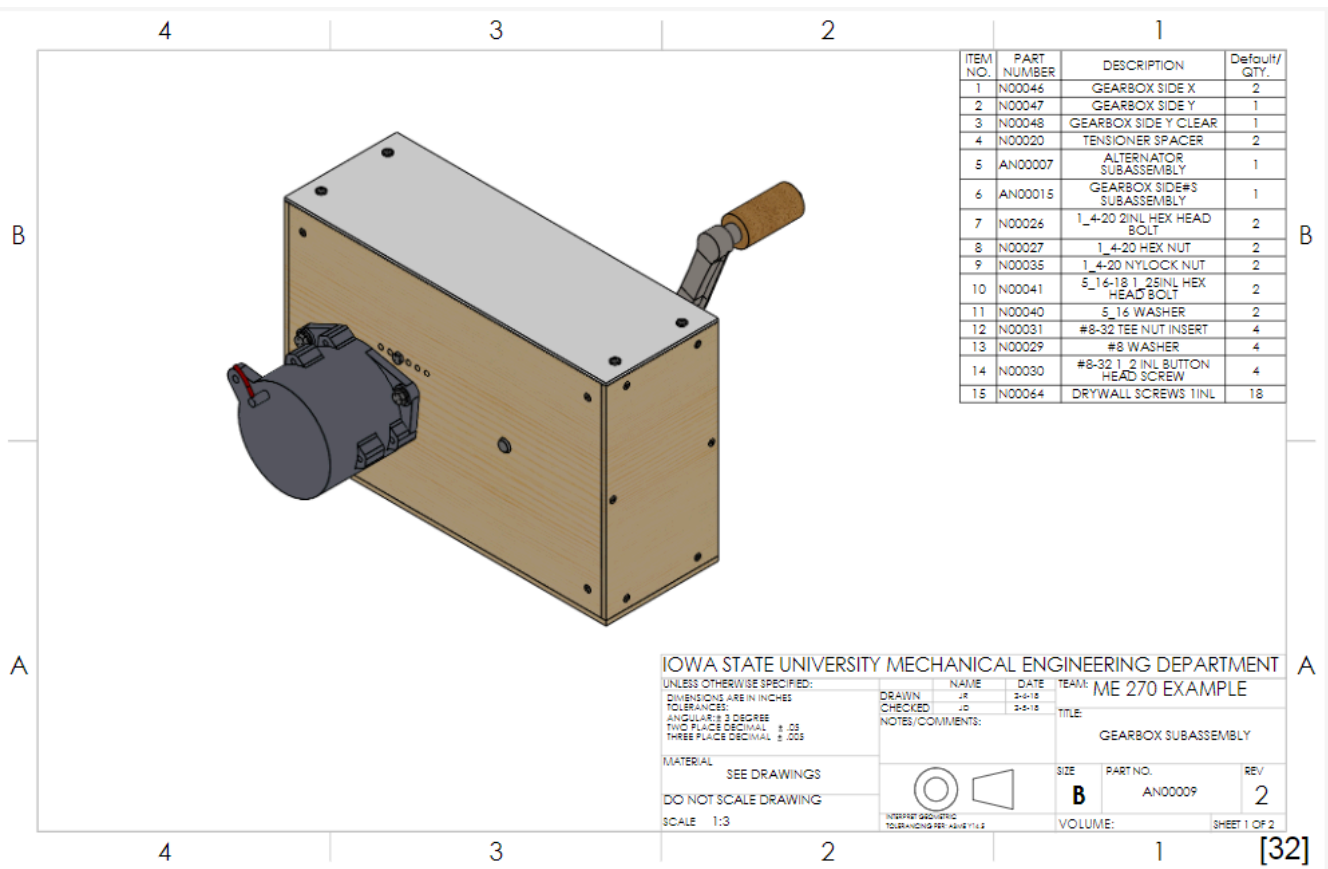

This picture/image shows a fully assembled gearbox engineering drawing example with bill of materials (BOM) in the upper right corner and title block in the lower right corner. Click on picture/image to review and/or download. Click on picture/image to review and/or download. I



## Part Drawing:

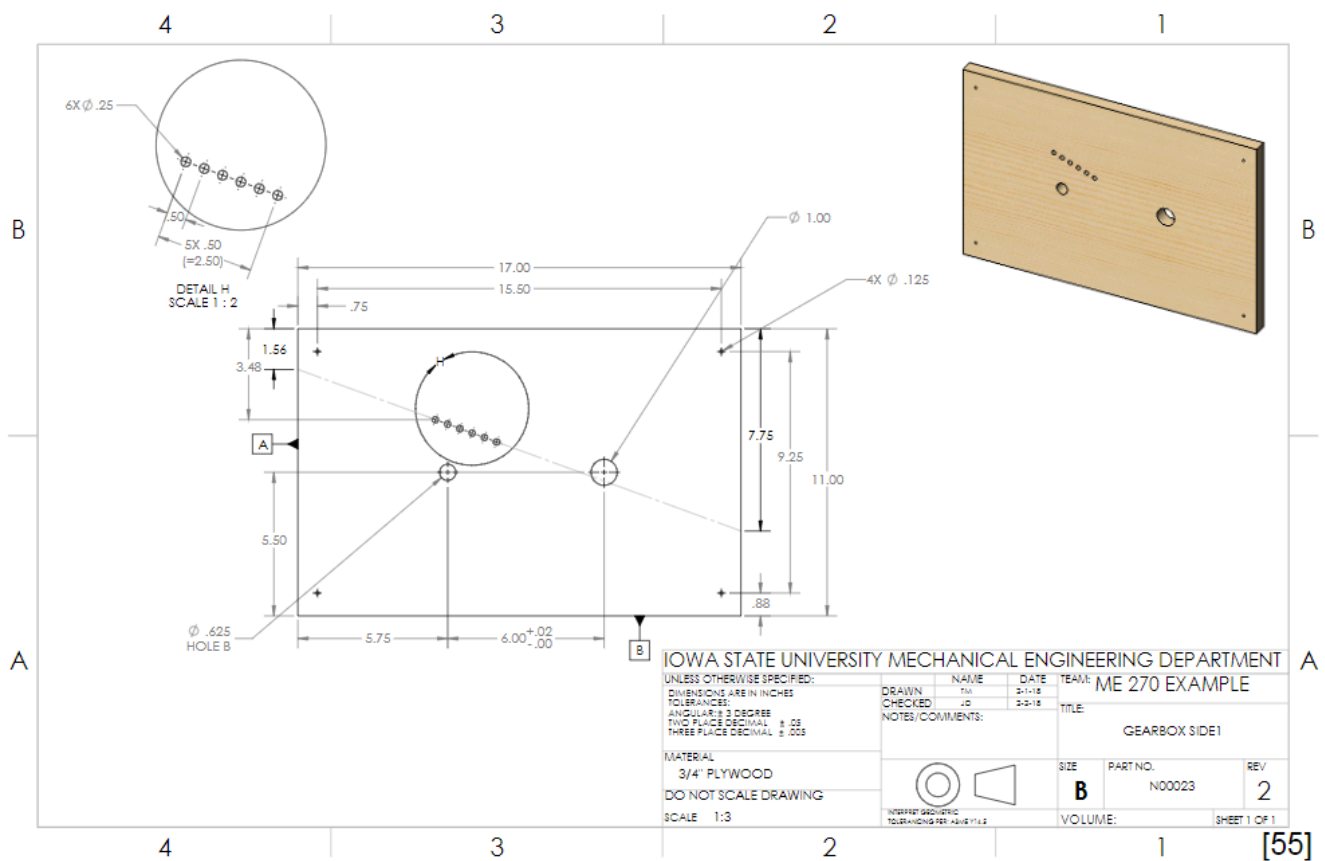

This picture/image is a Gearbox side 1 example part engineering drawing with dimensions for each angle. Shows the isometric view in the upper right corner, title block in the lower right corner, and dimensioned part in center area of the drawing. Click on the picture/image to view and/or download. Click on picture/image to review and/or download.

## Drawing title block fields:

1. Part number – must be in the lower right area of the template (make it long, because by default the filename becomes the drawing number in Solidworks. Our filenames are long)
2. Drawing Size
3. Drawing Revision Number or Letter
4. Sheet # of # – In ME 170, it is unlikely we get to multiple sheets. But, it could happen.
5. Description, Title or Name
6. Drawn by (Name and Date)
7. Checked by (Name and Date) – may be left blank
8. Drawing Scale

9. Material for part drawings. Left blank for assembly drawings.
10. The words, “INTERPRET GEOMETRIC TOLERANCING PER ASME Y14.5”
11. Graphic or note indicating “3rd Angle Projection.”
12. Tolerance block
13. A company would want to include a note, such as a Proprietary and Confidential info block that might say, “The information contained in this document is the property of [Company Name]. This document may not be reproduced in any manner without written permission.” This note is optional in ME 170.

**Note:** All required fields must have data/text in them unless specified by the instructor

*An interactive H5P element has been excluded from this version of the text. You can view it online here:*

<https://iastate.pressbooks.pub/me270baughman/?p=717#h5p-73>

# **MODULE 4B - DESIGN CONTINUED**

# Module 4B: Overview

---

## Module Objectives

1. **Module Objective 1:** Students will be able to prepare engineering drawings using engineering graphics/CAD software for the final design (CLO1, CLO2)
2. **Module Objective 2:** Students will identify the appropriate manufacturing/assembly processes for building a functional prototype (CLO1)
3. **Module Objective 3:** Students will be able to generate an expected profit and loss analysis using estimated costs and sales revenue(CLO1)
4. **Module Objective 4:** Students will develop a plan for manufacturing and distributing with estimated associated costs based on prototype (CLO1)
5. **Module Objective 5:** Students will be able to function effectively in selected role (CLO2)
6. **Module Objective 6:** Students will be able to evaluate (give examples of good) teamwork contribution and collaboration (CLO2)
7. **Module Objective 7:** Students will be able to justify own (self) teamwork contribution and collaboration (CLO2)
8. **Module Objective 8:** Students will be able to prepare structured summaries of design tool use and results that possess appropriate structure, grammar and tone (CLO3)
9. **Module Objective 9:** Students will identify locally sourced materials to use in the final engineering design prototype(CLO4)



## Module Highlights

In this module, students will review/read the content, including watching videos. Students will watch quiz-based/activity-based videos and complete test for understanding activities. This will prepare students for the teamwork activities of completing. Prior to fabrication/manufacture, the prototype design package must be reviewed to ensure manufacturability and

costing are aligned with constraints provided (prototype fits in rubber/tote container). Prior to fabrication/assembly, a full design-drawing package and corresponding fabrication plan MUST be reviewed and approved by Boyd Lab and Instructor/TA. Additionally a final prototype cost needs to be completed, along with a final BOM. Purchased parts must be approved and then entered into the Purchase Order form. A written draft of this section of the final report will be completed, as well as Peer Review 2. All student teams will need to be focused on utilizing roles/responsibilities and workload allocation per project plan. An industry perspective video (Vermeer Co.) on the design tools is included in this module.

## Materials, Activities and Assignments

- Read/review module content in sequential order as setup in Canvas
- Watch embedded and associated module videos
- Discuss in-class and on MS Teams the work progress to ensure work is completed and submitted per Canvas due date
- Utilize Canvas templates to complete work as outlined in assignment document
- Utilize Solidworks to complete CAD work as outlined in assignment document
- Consult with and obtain approval from Boyd Lab on final prototype design review package that includes prototype drawings AND MPIs
- Perform research and utilize cost analysis to complete P/L statement
- Submit module assignment(s):

### Prototype Final Design Review

The team must be focused on roles/responsibilities to complete this assignment. The subassembly design, MPIs and BOM with initial purchase order completed in Module 4A are critical input into this assignment. The Boyd Lab is the reviewer and approver of the engineering design drawing package. Consult with Boyd Lab as much as needed in order to obtain the final approval, without this, the prototype cannot be built. The team will need fully

utilize the roles/responsibilities to complete this assignment, which includes the approval of the final design package. The final prototype cost will be completed and will be used as input into the P/L statement for the prototype to determine profit or loss, as well as manufacturing and distribution plan.

In order to successfully complete this assignment, teams will need to allocate work, considering roles/responsibilities. This interaction may take place in the classroom and on Microsoft Teams. The team will complete the DMADVR toolbox template(s) and submit it to Canvas. This assignment will require teams to work together to get the major tasks completed. A key to success is consultation with the Boyd Lab on the engineering drawings and MPIs. As the experts in the Boyd Lab manufacturing equipment and capabilities, they will assist all teams in ensuring success during this process. Without Boyd Lab approval, the assignment is incomplete and no prototype building can be done. Consult with the Boyd Lab during class time as much as needed, based on availability of personnel. The teams will need to be respectful of other team sections, and do the consulting with Boyd only during this section, unless Boyd Lab allows it at another time. There are multiple sections and teams consulting with Boyd during their own sections class time, so please be aware of this constraint. It is important to focus on getting the design package completed and approved! The prototype build depends upon this! Time management is critical and the final report draft of this section is a component of the assignment that must be planned for as well!

This activity will help you to develop...

- **Module Objective 1:** Students will be able to prepare engineering drawings using engineering graphics/CAD software for the final design
- **Module Objective 2:** Students will identify the appropriate manufacturing/assembly processes for building a functional prototype
- **Module Objective 8:** Students will be able to prepare structured summaries of design tool use and results that possess appropriate structure, grammar and tone
- **Module Objective 9:** Students will identify locally sourced materials to use in the final engineering design prototype

## Task

In this assignment the teams will create engineering drawing package for final prototype design, follow the design package review process with Boyd Lab, develop final bill of materials (BOM)

needed to build/fabricate prototype, and determine final prototype cost (material and manufacturing costs), profit and loss, manufacturing & distribution plan. Prior to fabrication/manufacture, the prototype design package must be reviewed to ensure manufacturability and costing are aligned with constraints provided (prototype fits in rubber/tote container). Prior to fabrication/assembly, a full design-drawing package and corresponding fabrication plan MUST be reviewed and approved by Boyd Lab and Instructor/TA. Additionally a final prototype cost needs to be completed, along with a final BOM. Purchased parts must be approved and then entered into the Purchase Order form. The teams will prepare a written draft of this section of their final report.

## Grading Criteria

Grading is based on the “Submission Deliverables Expectations” outlined in the assignment document. This is reflected in the grading rubric available to students on the Canvas once the assignment is opened.

## Profit and Loss

Student teams will utilize their roles/responsibilities in this assignment to develop a plan for manufacturing and distribution of your product, estimate associated costs of running the business, estimate sales volumes needed to realize a net profit in the fourth year of the business, evaluate the sustainability of the business venture, and develop a draft of the final report for this section. The profit and loss statement summary will require teams to write about changes they would make to reduce costs and the how the current prototype supports the three pillars of sustainability.

In order to successfully complete this assignment, the teams must interact/discuss both in-class and on MS Teams (if needed) the roles/responsibilities that will lead to workload allocation in this assignment. The previous work in Modules 4A and 4B will be key inputs into this

assignment, and completing the DMADVR toolbox template by utilizing the instructions outlined in the assignment document will be critical to success. Developing the manufacturing and distribution plan will rely heavily on research about the target market and area from previous assignments in Modules 1 and 2. Also manufacturing equipment needed will also rely on previous Modules 4A and 4B.

This activity will help you to develop...

- **Module Objective 3:** Students will be able to generate an expected profit and loss analysis using estimated costs and sales revenue
- **Module Objective 4:** Students will develop a plan for manufacturing and distributing with estimated associated costs based on prototype
- **Module Objective 5:** Students will be able to function effectively in selected role
- **Module Objective 8:** Students will be able to prepare structured summaries of design tool use and results that possess appropriate structure, grammar and tone
- **Module Objective 9:** Students will identify locally sourced materials to use in the final engineering design prototype

## Task

Teams will complete a Profit and Loss statement utilizing the DMADVR toolbox templates. This template will require input from work in this module, as well as Module 4A on costing. Teams will make calculations based on the inputs, volumes are estimated which result is a profit by year 3 of production, and net profit and units sold are plotted versus years (See sample plot in the assignment). For the final report draft, the profit and loss template is analyzed, and an analysis of the sustainability of the design and the proposed business. The manufacturing and distribution plan is also discussed. In addition the team will need to discuss what changes they would make to reduce the total cost. The assignment requirements for all components is outlined in Parts A and B, as well as the Expectations of Assignment Deliverables.

## Grading Criteria

Grading is based on the “Expectations of Assignment Deliverables” outlined in the assignment document. This is reflected in the grading rubric available to students on the Canvas once the assignment is opened.



## Peer Review 2

Students will be assessing themselves and their team colleagues in Peer Review 2. The same set of evaluation questions as Peer Review 1. This Peer Review 2 assumes students have read through and reviewed the results from Peer Review 1. The students can address comments and the quantitative evaluation portions of the assessment. The students have the opportunity to discuss with the instructor at any time once they receive their results from any Peer Review. Peer Reviews are an important component of professional/team development.

This activity will help you to develop...

- Module Objective 5: Students will be able to function effectively in selected role (CLO2)
- Module Objective 6: Students will be able to evaluate (give examples of good) teamwork contribution and collaboration (CLO2)
- Module Objective 7: Students will be able to justify own (self) teamwork contribution and collaboration (CLO2)

### Task

Students will individually complete the CATME peer review online and follow the instructions outlined in the email sent to their ISU account from [catme.org](http://catme.org). The quantitative assessment must be completed, as well as, the qualitative assessment comments. The qualitative comments justify/explain the quantitative ratings for both team colleagues and self. Professional comments are important and need to be connected to the quantitative assessment given to all.

### Grading Criteria

Grading is based on the “Expectations Deliverables” outlined in the assignment document. This is reflected in the grading rubric available to students on the Canvas once the assignment is opened.

# Design Phase Cont'd

---

This portion of the Design phase will be focused on using estimated costs to develop a Profit/Loss statement (P&L statement). The BOM and prototype costing completed in Module 4A assignments will be key input into the P/L template. The determination of profitability will be completed in this phase.

A profit and loss statement (P&L), or income statement or statement of operations, is a financial report that provides a summary of a company's revenues, expenses, and profits/losses over a given period of time. The P&L statement shows a company's ability to generate sales, manage expenses, and create profits. It is prepared based on accounting principles that include revenue recognition, matching, and accruals, which makes it different from the cash flow statement.

## Typical Structure of the Profit and Loss Statement

A company's statement of profit and loss is portrayed over a period of time, typically a month, quarter, or fiscal year. The main categories that can be found on the P&L include:

- Revenue (or Sales)
- Cost of Goods Sold (or Cost of Sales)
- Selling, General & Administrative (SG&A) Expenses
- Marketing and Advertising
- Technology/Research & Development
- Interest Expense
- Taxes
- Net Income

# Chapter 4: BOM, Purchase Order and Part Cost

---

*An interactive H5P element has been excluded from this version of the text. You can view it online here:*

<https://iastate.pressbooks.pub/me270baughman/?p=684#h5p-69>

*An interactive H5P element has been excluded from this version of the text. You can view it online here:*

<https://iastate.pressbooks.pub/me270baughman/?p=684#h5p-34>

*An interactive H5P element has been excluded from this version of the text. You can view it online here:*

<https://iastate.pressbooks.pub/me270baughman/?p=684#h5p-35>

## Prototype Costing Analysis Accuracy

**In order to develop an accurate parts cost for the prototype, all parts MUST be accounted for on the BOM:**

1. Purchased Parts
2. Donated Parts
3. Fabricated parts

**Review CANVAS Assignments 08A and 08B to see what is needed for a Subassembly and Assembly review:**

1. The student design teams will have one formal in-class preliminary review prior to the final review date.
2. However, the teams are encouraged to reach out to the Boyd Lab as much as needed to ensure the final design review is approved on the due date!
3. Both Subassembly and Final Prototype Designs MUST be approved on time in order for the Boyd Lab to order materials for the manufacturing/assembly process.

# **MODULE 5 - VERIFY**

# Module 5: Overview

---

## Module Objectives

1. **Module Objective 1:** Students will be able to develop a prototype testing plan and analysis procedure (CLO1)
2. **Module Objective 2:** Students will apply a test analysis procedure for prototype testing (CLO1)
3. **Module Objective 3:** Students will be able to prepare structured summaries of design tool use and results that possess appropriate structure, grammar and tone (CLO3)
4. **Module Objective 4:** Students will be able to function effectively in selected role (CLO2)



## Module Highlights

In this module, students will review/read the content, including watching videos. Students will watch quiz-based/activity-based videos and complete test for understanding activities. This will prepare students for the teamwork activities of completing. The teams will be developing a test plan to test in order to test performance of their prototype. The testing plan can use the team's math model and/or DFMEA. The test plan will be implemented once the prototype is manufactured/assembled. The testing results will be analyzed and summarized. Two final report summaries will be produced for this section. An industry perspective video (Vermeer Co.) on the design tools is included in this module.

## Materials, Activities and Assignments

- Read/review module content in sequential order as setup in Canvas
- Watch embedded and associated module videos

- Discuss in-class and on MS Teams the work progress to ensure work is completed and submitted per Canvas due date
- Utilize Canvas templates to complete work as outlined in assignment document
- Consult with Boyd Lab about your testing plan to ensure equipment available
- Develop a test plan and implement it, and adjust testing if needed based on findings and/or other issues found during fabrication/manufacturing and testing
- Complete an ECN when changes are made during testing
- Submit module assignment(s):

## Testing Plan

The team must be focused on roles/responsibilities to complete this assignment. In order to successfully complete this assignment, teams will need to allocate work, considering roles/responsibilities. This interaction may take place in the classroom and on Microsoft Teams. The team will complete the DMADVR toolbox template(s) and submit to Canvas. A key to success is consultation with the Boyd Lab on test plans to ensure feasibility and equipment availability. The teams will need to be respectful of other team sections, and consult with Boyd only during this section or discuss with lab personnel. There are multiple sections and those teams also are consulting with Boyd during their class time. Time management is critical in getting testing completed & analyzed, and the final report drafts of this section.

**Hint:** Team roles and responsibilities are important and critical particularly at this part of the design process. Teams may have team members allocated to working on testing results & analysis, profit and loss assignment (previous module), and drafting summaries.

This activity will help you to develop...

- **Module Objective 1:** Students will be able to develop a prototype testing plan and analysis procedure (CLO1)
- **Module Objective 3:** Students will be able to prepare structured summaries of design tool use and results that possess appropriate structure, grammar and tone (CLO3)
- **Module Objective 4:** Students will be able to function effectively in selected role (CLO2)

## Task

In this assignment the teams will create a test plan. The test plan may be based on the team's math model, specifications and DFMEA. Team will develop tests that will collect important information needed to verify/refine design concept, propose step-by-step testing procedures, material requirements, equipment needed, test schedules, safety procedures, and data collection methods. The team is required to develop 3 tests for their prototype. A minimum of two test MUST be quantitative and one can be qualitative. Teams will need to identify independent and dependent variables, and are encouraged to create “dummy” graphs showing this to be populated when testing is completed.

Keys to success are the team's allocation of work on tasks based on roles/responsibilities. The testing plan will also be more successful with consultations with the Boyd Lab to ensure the test is feasible and that equipment is available to perform a test. The test plan identifies specific test objectives, procedures, equipment, schedules, and expected outcomes to confirm the prototype design will function as intended. Test plan should provide enough detail so that a technician could take your plan and implement the tests without further instruction from you.

## Grading Criteria

Grading is based on the “Submission Deliverables Expectations” outlined in the assignment document. This is reflected in the grading rubric available to students on the Canvas once the assignment is opened.

## Prototype Fabrication Results and Testing Analysis

In this assignment, teams will document the fabrication process, any revisions made to that process, and testing results. During the fabrication process, the team may discover that a change needs to be made, this may or may not impact the testing plan. If changes need to be made teams will complete an Engineering Change Notice (ECN) and obtain signature from the

instructor to approve the change. All changes will be documented and included in the written summary. This documents the results of both the fabrication process and testing. This is documentation that design teams need in industrial settings, and is important for record-keeping!

In order to successfully complete this assignment, the teams must interact/discuss both in-class and on MS Teams (if needed) the roles/responsibilities that will lead to workload allocation in this assignment. During the fabrication process, if changes need to be made to the design, and/or testing, this must be completed and documented. This involves the roles/responsibilities that team members have. This is a critical portion of the design process, as key information/data are utilized to make changes, if needed, that may result in improvements and a better understanding of the prototype design. The team will learn about their design during the fabrication/manufacturing and testing tasks.

This activity will help you to develop...

- **Module Objective 2:** Students will apply a test analysis procedure for prototype testing (CLO1)
- **Module Objective 3:** Students will be able to prepare structured summaries of design tool use and results that possess appropriate structure, grammar and tone (CLO3)
- **Module Objective 4:** Students will be able to function effectively in selected role (CLO2)

## Task

Teams will complete the fabrication/manufacturing of the designed prototype and document any changes to the design, as well as, make the changes (CAD, materials, processes, etc.). If this impacts the testing plan, the teams must make changes, and document this. Prior to any changes, they must be approved by the instructor by using an Engineering Change Notification (ECN). A written summary of this section for the final report will also be completed.

## Grading Criteria

Grading is based on the “Expectations of Assignment Deliverables” outlined in the assignment document. This is reflected in the grading rubric available to students on the Canvas once the assignment is opened.



# Verify Phase

---

During the Verify Phase, the team introduces the design of the product or process and performs the validation testing to verify that it does meet customer and performance requirements. A prototype testing plan is developed and results obtained. After the prototype is built/assembled, the testing plan is implemented to verify the design meets customer and performance requirements developed per the plan. This phase includes development of a test plan, implementation of the test plan on a manufactured/built/assembled prototype, results obtained and analyzed, and may also include ECN (engineering change notice) from testing results and/or manufacturing (build) process.



Engineering design testing



Engineering Design Testing

# Chapter 1: Test Planning and Results

---

## Watch the Interactive Video: Test Planning Overview

An interactive H5P element has been excluded from this version of the text. You can view it online here:

<https://iastate.pressbooks.pub/me270baughman/?p=1482#h5p-67>

## Testing Inferences

Suppose you tested your prototype with independent variable “A” at level  $a$ , and an observed dependent variable “B” at level  $b$ .

What happens for other levels of A? Did you measure for everything that changed, which may have been more than just A?

Looking back at the studying example, your independent variables of study time and location may affect more than just your test score. For example, they may also affect your homework scores. Could the result simply be due to “random chance”?

## Hypotheses

A **hypothesis** is a testable statement that predicts observable phenomena. It comprises two parts:

- What happens to  $B$  when  $A$  is changed?
- What happens to  $B$  when  $A$  is **not** changed?

A famous hypothesis is that objects of different weights fall at the same rate. A hypothesis we can make about studying is that studying longer with peers will improve your test score.

When evaluating a hypothesis, it can be accepted (true) or rejected (false).

**Hypotheses give us testable and systematic explanations for observable phenomena and help to focus our attention during testing.** The knowledge gained from testing a hypothesis

provides rigorous support for further experiments and design decisions. The data gained can prove or disprove a hypothesis using statistical analysis.

### Watch the Video: Test Plan Example

*An interactive H5P element has been excluded from this version of the text. You can view it online here:*

<https://iastate.pressbooks.pub/me270baughman/?p=1482#h5p-68>

## Three Test Plans and Results: Corn Grinder Prototype Example in ME 270

Click on the link below to download and review three examples of test plans and results using the ME 270 DMADVR toolbox template. The test plan is the first item shown, and scrolling down that same page are the testing results for each of the tabbed tests #1-3. This example is also available Canvas Modules 0 & 00, Module 1 Quiz and Assignments, and Resources.

[Three test plans and results examples](#)

## Data Analysis

Once the data is collected from the tests, it can be subjected to data analysis. Some common methods of statistical analysis are:

- Measures of central tendency- mean, median, and mode
- Measures of deviation from central tendency- variance, standard deviation
- Regression- Fitting models to data, linear, log-linear, log-log, etc.

*An interactive H5P element has been excluded from this version of the text. You can view it online here:*

<https://iastate.pressbooks.pub/me270baughman/?p=1482#h5p-76>

# Chapter 2: Prototype Manufacture/Fabricate/Assemble

---

## Addressing “Issues” Found during the Manufacturing Process: An ECN Form

When purchased parts arrive, the Boyd Lab typically places them in the team totes. Check your totes to see if your purchased parts have come in within a week or perhaps earlier. If you're missing something, please contact the Boyd Lab.

During the building of your prototype, there are typically issues with dimensions or materials or even manufacturing processes. If this occurs, an Engineering Change Notice (ECN) is required, and please see the DMADV Toolbox for the ECN form. It requires a review with the team and signature of the instructor.

ECNs are common during initial builds (manufacturing, processing, etc.) and sometimes testing in industry settings. This helps to improve our design, manufacturing, and testing of our product (prototype). It can also improve performance of our final design/product.

## ECN FORM -Click down the left side to preview content areas of the form

*An interactive H5P element has been excluded from this version of the text. You can view it online here:*

<https://iastate.pressbooks.pub/me270baughman/?p=1507#h5p-82>

 <b>ME 270 Engineering Change Notification (ECN)</b>	
<b>Team:</b> _____	<b>Section:</b> _____
This form must be filled out and signed before any significant fabrication change is implemented.	
<b>Requester:</b> _____	<b>Date:</b> _____
<b>Current Issue:</b>	
<b>Proposed Change(s):</b> (Note: New components or assemblies require drawing(s) to be attached)	
Instructor or TA signature:	
<b>Instructor's / TA's comments:</b>	

Provided here is an example of what the Engineering Change Notification (ECN) Form looks like.

An interactive H5P element has been excluded from this version of the text. You can view it online here:  
<https://iastate.pressbooks.pub/me270baughman/?p=1507#h5p-75>

# **MODULE 6 - REPORT RESULTS**

# Module 6: Overview

---

## Module Objectives

1. **Module Objective 1:** Students will be able to function effectively in selected role (CLO2)
2. **Module Objective 2:** Students will be able to evaluate (give examples of good) teamwork contribution and collaboration (CLO2)
3. **Module Objective 3:** Students will be able to justify own (self) teamwork contribution and collaboration (CLO2)
4. **Module Objective 4:** Students will be able to explain the final design concept process to others using written and oral presentation methods (CLO2)
5. **Module Objective 5:** Students will be able to explain/communicate the engineering design process results to diverse audiences (CLO2, CLO3, CLO4)
6. **Module Objective 6:** Students will be able to seek assistance for teamwork and conflict resolution (CLO2)
7. **Module Objective 7:** Students will be able to prepare structured summaries of design tool use and results that possess appropriate structure, grammar and tone(CLO3)
8. **Module Objective 9:** Students will be able to explain/communicate the impact of incorporating the three pillars of sustainability in the final design (CLO4)



## Module Highlights

In this module, students will review/read the content, including watching videos. Students will watch quiz-based/activity-based videos and complete test for understanding activities. This will prepare students for the teamwork activities/tasks to complete assignments. This module is focused teams preparing to communicate the design process and results. Teams will present their design process results to diverse audiences using presentation and written methods. This module is the culmination of the semester's journey for the teams, and the resultant output.

## Materials, Activities and Assignments

- Read/review module content in sequential order as setup in Canvas
- Watch embedded and associated module videos
- Discuss in-class and on MS Teams the work progress to ensure work is completed and submitted per Canvas due date
- Utilize Canvas templates to complete work as outlined in assignment document
- Develop a poster and schedule for the ME Design Expo, final presentation, and report
- Submit module assignment(s):

### Design Expo Poster

The team must be focused on roles/responsibilities to complete this assignment. In order to successfully complete this assignment, teams will need to allocate work, considering roles/responsibilities. The poster will be a summary of the semester's design journey by the team. The DFSS process will be summarized and the DMADV tools will be highlighted.

This activity will help you to develop...

- **Module Objective 1:** Students will be able to function effectively in selected role (CLO2)
- **Module Objective 4:** Students will be able to explain the final design concept process to others using written and oral presentation methods (CLO2)
- **Module Objective 5:** Students will be able to explain/communicate the engineering design process results to diverse audiences (CLO2, CLO3, CLO4)
- **Module Objective 9:** Students will be able to explain/communicate the impact of incorporating the three pillars of sustainability in the final design (CLO4)

### Task

The Department of Mechanical Engineering hosts a DESIGN EXPO every semester allowing student design teams to show off the work they have accomplished. It is also an opportunity for the department to show others (students, faculty, and public) what mechanical engineering design is about. This is your team's best opportunity to market your design to others. In this



assignment the teams will create a ME Design Expo poster that summarizes the design process results. This poster will be presented to diverse audiences and the team will also have their prototype at the Design Expo. The team members will have a schedule for different team members to staff their Design Poster and Prototype location. The Design Expo includes all sections of ME 270.

Keys to success on this assignment is to allocate work and to maximize the roles/responsibilities within the team. The team's schedule will be key to ensure that there is coverage at their ME Design Expo location to answer questions that might be asked by a diverse audience.

The Team must submit a poster using the PPTX template provided in Canvas and provide a schedule indicating who will be transporting the prototype to the EXPO, who will be staffing your stand/display at given times for the DESIGN EXPO, and who will clean up. Each team must assist in breaking down the displays and returning projects to classroom.

## Grading Criteria

Grading is based on the “Submission Deliverable(s) Expectations” outlined in the assignment document. This is reflected in the grading rubric available to students on the Canvas once the assignment is opened.

## Final Presentation with Voice-Over Video

In this assignment, teams will develop a final presentation that will include the incorporation of a voice-over video that highlights the functionality of the design. Teams have flexibility with the voice-over video. The video could be completed by utilizing CAD animation/motion study or a video of the prototype's functionality while going through the testing process.

In order to successfully complete this assignment, the teams must interact/discuss both in-class and on MS Teams (if needed) the roles/responsibilities that will lead to workload allocation in this assignment. The teams have a lot of flexibility in the video production, and are encouraged to share ideas in consultation with the instructor. The assignment provides the time constraints

and specific instructions. A key success factor is to follow the instructions in the assignment and consult with the instructor when questions/concerns arise, and clarity is needed.

This activity will help you to develop...

- **Module Objective 1:** Students will be able to function effectively in selected role (CLO2)
- **Module Objective 4:** Students will be able to explain the final design concept process to others using written and oral presentation methods (CLO2)
- **Module Objective 5:** Students will be able to explain/communicate the engineering design process results to diverse audiences (CLO2, CLO3, CLO4)
- **Module Objective 9:** Students will be able to explain/communicate the impact of incorporating the three pillars of sustainability in the final design (CLO4)

## Task

Teams will develop a presentation of a final design based on work throughout the semester. Teams develop a voice-over video highlighting prototype functionality. The final presentation will include the incorporation of the video. The final presentation format and content is outlined in the assignment document.

## Grading Criteria

Grading is based on the “Expectations of Assignment Deliverables” outlined in the assignment document. This is reflected in the grading rubric available to students on the Canvas once the assignment is opened.

## Final Report and Template

In this assignment, teams will develop a final report utilizing the final report template. To complete the assignment, teams must interact/discuss both in-class and on MS Teams (if needed) the roles/responsibilities that will lead to workload allocation in this assignment. Proper

documentation and reporting is extremely important for design engineering projects. In ME 270, you are reporting on your project at the Design Expo, a final presentation, and a final report. These documents will be used by future students who can learn from your work. Your audience for the report are key stakeholders or people who have technical knowledge of mechanical engineering, and/or are familiar with your project throughout the semester.

Keys to success are to allocate the work tasks and to utilize the summaries that have been developed throughout the semester. These are key inputs into the final report. Following the template provided ensure that the content required is included in the report. The team will have components that were completed by the previous allocation of work task based on the roles/responsibilities, and completing the final report will be a team-based effort.

This activity will help you to develop...

- **Module Objective 1:** Students will be able to function effectively in selected role (CLO2)
- **Module Objective 4:** Students will be able to explain the final design concept process to others using written and oral presentation methods (CLO2)
- **Module Objective 5:** Students will be able to explain/communicate the engineering design process results to diverse audiences (CLO2, CLO3, CLO4)
- **Module Objective 9:** Students will be able to explain/communicate the impact of incorporating the three pillars of sustainability in the final design (CLO4)

## Task

Teams will develop an engineering design team final report based on the results of the semester's journey. The team will propose a final design based on improvements/modifications that needed to be made during the fabrication and/or testing phase. The team will create a business plan to document viability and development of the design. The final report will document the DFSS design process, and communicate this project, results, and proposed design improvements.

## Grading Criteria

Grading is based on the "Expectations of Assignment Deliverables" outlined in the assignment document. This is reflected in the grading rubric available to students on the Canvas once the assignment is opened.

## Peer Review 3

In this assignment, students will individually complete a peer assessment of team colleagues and self. This assignment will help you learn more about how your peers perceive your contributions to teamwork, interaction with teammates, efforts to keep team on track, and expectations for quality.

Keys to success on this assignment are for students to both quantitatively rate their team colleagues and themselves, and qualitatively by providing comments to back up their ratings.

This activity will help you to develop...

- **Module Objective 1:** Students will be able to function effectively in selected role (CLO2)
- **Module Objective 2:** Students will be able to evaluate (give examples of good) teamwork contribution and collaboration (CLO2)
- **Module Objective 3:** Students will be able to justify own (self) teamwork contribution and collaboration (CLO2)
- **Module Objective 6:** Students will be able to seek assistance for teamwork and conflict resolution (CLO2)

### Task

Students will individually complete the online peer review using CATME, and follow the instructions sent to their ISU email account from catme.org. The peer ratings and comments are both required to ensure a professional focused final peer review is completed.

### Grading Criteria

Grading is based on the “Expectations of Deliverables” outlined in the assignment document. This is reflected in the grading rubric available to students on the Canvas once the assignment is opened.

# Report Phase

---

When working in engineering, you will often need to discuss plans or designs with others. The ability to clearly communicate is essential to collaborative work. It is particularly important when working with non-engineers, as the engineer must take technical information and convey it clearly to those without advanced technical knowledge. This way, progress and options are understood by everyone involved.

Proper documentation and reporting is extremely important for design engineering projects. In ME 270, you are reporting on your project at the Design Expo, a final presentation, and a final report. These documents will be used by future students who can learn from your work. Your audience for the report are key stakeholders or people who have technical knowledge of mechanical engineering, and/or are familiar with your project throughout the semester.

# Chapter 1: Design Results Reporting

---

## Reporting Results

This phase includes reporting results of the DFSS journey throughout the semester. These results are typically presented to diverse stakeholder audiences via:

### ME Design Expo poster with prototype display

Poster: Visual Representation of the Design Process and Final Design Result to a diverse audience reviewing your poster! **Example Poster:** [Grinder Poster \[PDF\]](#)

### Final presentation

- PowerPoint Guidelines to improve presentation quality: [WOVE \[ppt\]](#)
- Final Presentation Example (Not Perfect) but Content is important. This presentation was completed prior the the WOVE guidelines provided above: [Final Presentation ME 270-1 Example \[ppt\]](#)

**Watch this humorous presentation by an engineer and comedian!**

*One or more interactive elements has been excluded from this version of the text. You can view them online here:*  
<https://iastate.pressbooks.pub/me270baughman/?p=2103#oembed-1>

[My Favorite Charts – Humor Video Script \[DOC\]](#)

### Final report

- Propose a final design based on your work throughout the semester
- Create a business plan to document the viability and development of your design
- Prepare a final report that clearly documents DFSS design process
- Communicate and document the DFSS design project, results, and proposed design improvements

The team's audience for the report include key stakeholders or people who have technical knowledge of mechanical engineering, and/or are familiar with your project throughout the semester. Proper documentation and reporting is extremely important for design engineering projects. Professional written communication of your semester's design work and results!

**Follow the Final Design Report Assignment Document for final report development and submission**

# Appendix 1: Accessibility Assessment

---

Below is a short assessment of eight key areas where accessibility has been assessed during the production process of this textbook. The [accessibility checklist](#) has been drawn from the [BCcampus Open Education Accessibility Toolkit](#). While a checklist such as this is just one part of a holistic approach to accessibility, it is one way to begin our work on embedded good accessibility practices in the books we support.

Wherever possible, we have identified ways in which anyone may contribute their expertise to improve the accessibility of this text.

We also welcome any feedback from students, instructors or others who encounter the book and identify an issue that needs resolving.



### Accessibility Checklist

Category	Item	Status
<b>Organizing Content</b>	Content is organized under headings and subheadings	X
<b>Organizing Content</b>	Headings and subheadings are used sequentially (e.g. Heading 1, Heading 2, etc.) as well as logically (if the title is Heading 1 then there should be no other Heading 1 styles as the title is the uppermost level)	X
<b>Images</b>	Images that convey information include Alternative Text (alt-text) descriptions of the image's content or function	X
<b>Images</b>	Graphs, charts, and maps also include contextual or supporting details in the text surrounding the image	X
<b>Images</b>	Images, diagrams, or charts do not rely only on color to convey important information	X
<b>Images</b>	Images that are purely decorative contain empty alternative text descriptions. (Descriptive text is unnecessary if the image doesn't convey contextual content information)	X
<b>Tables</b>	Tables include column headers, and row headers where appropriate	X
<b>Tables</b>	Tables include a title or caption	X
<b>Tables</b>	Tables do not have merged or split cells	X
<b>Tables</b>	Tables have adequate cell padding	X
<b>Weblinks</b>	The weblink is meaningful in context, and does not use generic text such as "click here" or "read more"	X
<b>Weblinks</b>	Weblinks do not open new windows or tabs	X
<b>Weblinks</b>	If weblinks must open in a new window, a textual reference is included in the link information	X
<b>Embedded Multimedia</b>	A transcript has been made available for a multimedia resource that includes audio narration or instruction	X
<b>Embedded Multimedia</b>	Captions of all speech content and relevant non-speech content are included in the multimedia resource that includes audio synchronized with a video presentation	X
<b>Embedded Multimedia</b>	Audio descriptions of contextual visuals (graphs, charts, etc.) are included in the multimedia resource	N/A
<b>Formulas</b>	Formulas have been created using MathML	N/A
<b>Formulas</b>	Formulas are images with alternative text descriptions, if MathML is not an option	N/A
<b>Font Size</b>	Font size is 12 point or higher for body text	X

<b>Category</b>	<b>Item</b>	<b>Status</b>
<b>Font Size</b>	Font size is 9 point for footnotes or endnotes	X
<b>Font Size</b>	Font size can be zoomed to 200%	X